



Community Advisory Council

APCD CAC Members

Dennis Beebe
Dave Davis
Katie Davis
Cliff Dugger
Matt Dunn
Jennifer Fullerton
Lee Heller
Dillon Kass
Michael Lopez
Edward McGowan
Badaoui Mouderrres
Laura Nuzzo
Ben Oakley
David Rose
Dave Savinsky
Patrice Surmeier,
Vice Chair
Jim Taylor
Randy Westhaus
Murry Wilson

APCD CAC Chair:
Aeron Arlin Genet

AGENDA

SPECIAL MEETING
November 2, 2023
4:00 P.M.

Sideways Inn
114 East Highway 246
Buellton, CA
Vintage Hall

Pursuant to Government Code Section 54954.3(a), members of the public may address the CAC on any matter listed on the agenda before the item is considered. Matters not listed on the agenda may be addressed during the public comment period. The CAC will consider any and all public comments related to the mission of the APCD and/or the Charter of the CAC.

Additional information, including Agendas, Supplemental Materials, and Minutes of the CAC, can be obtained on the APCD District website at: <https://www.ourair.org/community-advisory-council-info/>.

Any disclosable public records related to an open session item on the meeting agenda and distributed by the Board Clerk to all or a majority of the members of the CAC less than 72 hours prior to that meeting are available for inspection in the APCD office or website. CAC meetings are audio recorded; recordings will be made available upon request pursuant to the California Public Records Act. In compliance with the Americans with Disabilities Act, individuals needing special accommodations to participate in the meeting should contact the APCD at (805) 979-8050 at least three working days prior to the scheduled meeting.

- A. 4:00 p.m. – Convene**
- B. Roll Call**
- C. Public Comment Period** – *Persons desiring to address the CAC on any subject within the jurisdiction of the CAC not included as part of the agenda may do so at this time.*
- D. Approval of Minutes of the August 23, 2023 meeting.**
- E. Organization of Agenda**
- F. APCO Report**
- G. NEW BUSINESS** – *Declaration of Interest to be conducted prior to each item.*
 - G-1) *Receive and file an update on the Assembly Bill 617 BARCT Analysis for Gas Turbines and Associated Duct Burners.*
 - G-2) *Receive and file a presentation on District Rule 210 - Fees.*
- H. Adjourn**



Community Advisory Council

Meeting Minutes (Unofficial)

August 23, 2023

**Buellton Community Recreation Center
301 Second Street
Buellton, CA
Room A**

APCD CAC Members

Dennis Beebe
Janet Blevins
Dave Davis
Katie Davis
Cliff Dugger
Matt Dunn
Jennifer Fullerton
Lee Heller
Dillon Kass
Michael Lopez
Edward McGowan
Badaoui Mouderrres
Laura Nuzzo
Ben Oakley
John Reaves
David Rose
Dave Savinsky
Patrice Surmeier,
Vice-Chair
Jim Taylor
Randy Westhaus
Murry Wilson

APCD CAC Chair:
Aeron Arlin Genet

A. Convene

The meeting was called to order at 4:06 p.m

B. Roll Call

Present: 10 - Beebe, K. Davis, Heller, Kass, McGowan, Mouderrres, Nuzzo, Rose, Surmeier, Taylor.

Absent: 11 - Blevins, D. Davis, Dugger, Dunn, Fullerton, Lopez, Oakley, Reaves, Savinsky, Westhaus, Wilson.

Staff: 7 - Aeron Arlin Genet, Dave Harris, Alex Economou, Jim Fredrickson, Tim Mitro, and Lorena Saldana.

C. Public Comment Period – *Persons desiring to address the CAC on any subject within the jurisdiction of the CAC not included as part of the agenda may do so at this time.*

There were no public comments.

D. Approval of Minutes of the February 22, 2023 meeting.

A motion was made by Lee Heller, seconded by Badaoui Mouderrres to approve all the minutes as submitted. The motion carried by the following vote:

Ayes: 10 - Beebe, K. Davis, Heller, Kass, McGowan, Mouderrres, Nuzzo, Rose, Surmeier, Taylor.

Noes: 0 - None.

Abstain: 0 - None.

Absent: 11 - Blevins, D. Davis, Dugger, Dunn, Fullerton, Lopez, Oakley, Reaves, Savinsky, Westhaus, Wilson.

E. Organization of Agenda

There was no change to the organization of the agenda.

F. APCO Report

Received report.

G. NEW BUSINESS – Declaration of Interest to be conducted prior to each item.

G-1) *Receive and File an update on the Assembly Bill 617 BARCT Analysis for Miscellaneous Combustion Units.*

Received item.

Interest: None.

H. Adjourn

The meeting was adjourned at 5:02 p.m.

COMMUNITY ADVISORY COUNCIL

ATTENDANCE – 2023

A Quorum of the CAC shall be a majority of the appointed members minus one. Vacant positions shall not count toward a quorum.

NAME	Appointing Board Member	JAN+ 6	FEB+ 2	FEB 22	MAR' 22	APR' 26	MAY' 24	JUN' 28	JUL' 26	AUG 23	SEP 27	OCT 25	NOV 22	DEC 27
Dennis Beebe	Infanti	Yes	Yes	Yes						Yes				
Janet Blevins	Hartmann	No	No	No						No				
Dave Davis	Capps	Yes	Yes	Yes						No				
Katie Davis	Rowse	Yes	Yes	No						Yes				
Cliff Dugger	Nelson	Yes	No	Yes						No				
Matt Dunn	Perotte	Yes	Yes	Yes						No				
Jennifer Fullerton	Perotte	Yes	No	No						No				
Lee Heller	Capps	Yes	Yes	Yes						Yes				
Dillon Kass	Patino	No	Yes	Yes						Yes				
Michael Lopez	Clark	No	Yes	Yes						No				
Edward McGowan	Williams	*	*	*						Yes				
Badaoui Mouderrès	Williams	*	*	*						Yes				
Laura Nuzzo	Nelson	No	Yes	Yes						Yes				
Ben Oakley	Lavagnino	Yes	Yes	Yes						No				
John Reaves	Hartmann	No	No	No						No				
David Rose	Lavagnino	*	*	*						Yes				
David Savinsky	King	*	Yes	Yes						No				
Patrice Surmeyer	Julian	Yes	Yes	Yes						Yes				
Jim Taylor	Clark	Yes	Yes	Yes						Yes				
Randy Westhaus	Patino	Yes	Yes	Yes						No				
Murry Wilson	Julian	No	Yes	Yes						No				

Members Present	11	14	14							10				
Members Absent	6	4	4							11				

1 There was no CAC meeting.
 * Not yet appointed/resigned/inactive/term ended
 ♦ Special Meeting



MEMORANDUM

DATE: October 20, 2023

TO: Community Advisory Council (CAC) Members

FROM: Alex Economou, (805) 979-8333, AJE@sbcapcd.org

SUBJECT: AB 617 BARCT Analysis for Gas Turbines and Associated Duct Burners

Background

Assembly Bill (AB) 617, enacted in July 2017, has many requirements to address the disproportionate impacts of air pollution in environmental justice communities. One of the key components of AB 617 is to reduce air pollutant emissions from facilities that participate in the California Greenhouse Gas (GHG) Cap-and-Trade system. There are six of these industrial facilities within Santa Barbara County, and AB 617 requires these facilities to implement Best Available Retrofit Control Technology (BARCT).

During the initial BARCT assessment in 2018, the District reviewed the permitted gas turbines at the AB 617 industrial sources to see if additional controls would be feasible. The District's preliminary review showed that it may be feasible and cost-effective to establish new BARCT standards for gas turbines subject to AB 617 within Santa Barbara County. Hence, the District included a new rule (District Rule 358) on the District's AB 617 schedule as a measure that needed to be fully evaluated for BARCT. The BARCT schedule was adopted by the District Board in December 2018.

Out of the six AB 617 industrial facilities in Santa Barbara County, ExxonMobil's Las Flores Canyon Oil and Gas Plant is the only facility that has permitted equipment subject to this BARCT analysis for Gas Turbines and Associated Duct Burners. The Las Flores Canyon Oil and Gas Plant is located approximately 20 miles west of Santa Barbara. However, due to the 2015 rupture of the Plains All American Pipeline, the facility has been shut-in and maintained in a preserved state until a permitted means of transporting the oil is identified. The air quality operating permit for the facility remains current and active.

Discussion

District staff compiled the draft BARCT analysis for Gas Turbines and Associated Duct Burners, as shown in Attachment A, that demonstrates a technologically feasible and cost-effective option for the 49 megawatt (MW) combined-cycle, cogeneration power plant at Las Flores Canyon to comply with lower NO_x limits. The power plant's NO_x emission limit would be reduced from 7.4 ppmv (parts per million by volume, corrected to 15% oxygen) to 2.0 ppmv, which would result in approximately 19 tons of NO_x reductions per year if the equipment was operating near its operational baseline.

Although the Las Flores Canyon facility is currently not operating, ExxonMobil submitted two permit applications to comply with the BARCT analysis by incorporating new, enforceable conditions into its Permit to Operate (PTO). The Authority to Construct (ATC) permit will allow modifications to the turbine system to implement the BARCT requirements, and the PTO-Modification/Part 70 Minor Modification will incorporate the BARCT emission standards into the Part 70 operating permit for the Las Flores Canyon facility. The permit applications were deemed complete, and once issued, will have enforceable conditions that require the facility to comply with the BARCT conditions prior to the facility recommencing operations. The facility is anticipated to achieve the lower NOx standard by retrofitting the existing Selective Catalytic Reduction (SCR) system to achieve higher control efficiencies.

The BARCT requirements would also apply to any new units installed at the six AB 617 industrial facilities. This is because BARCT is an emission standard that is not limited to just “retrofits.” However, if new turbine systems were proposed for use at the AB 617 industrial facilities, they would be evaluated for Best Available Control Technology (BACT), which is equal to or more stringent than the requirements in this BARCT analysis. Hence, this BARCT analysis is not anticipated to have an effect on the remaining AB 617 industrial facilities.

Since all BARCT requirements will be incorporated directly into ExxonMobil’s operating permit, Staff affirms that it is no longer necessary to adopt a new rule to implement the BARCT requirements. Staff propose to bring the BARCT analysis before the District Board of Directors to finalize this assessment. Once finalized, the BARCT analysis will continue to apply to ExxonMobil’s existing equipment units, as well as any new combined-cycle, cogeneration power plants installed in the future at any of the AB 617 industrial facilities to ensure that NOx emissions are effectively controlled. In addition, the BARCT analysis will be forwarded to the California Air Resources Board for inclusion into their AB 617 BARCT webpage (ww2.arb.ca.gov/expedited-barct). Staff worked with District Counsel and concluded that this approach effectively satisfied the AB 617 mandate because it accomplishes the emission reduction goals of the legislation.

For the CAC meeting on November 2, 2023, Staff will provide a presentation on the key points of the BARCT analysis and ExxonMobil’s request to comply with the analysis through enforceable permit conditions. This agenda item will be informational only (i.e., no formal CAC recommendation will be sought). The docketed materials are also available for review from the District’s website, www.ourair.org/rules-under-development, and all six AB 617 industrial facilities have been noticed about this meeting.

If there are questions or concerns that you would like to discuss prior to the meeting, please contact me or Tim Mitro at (805) 979-8329 / e-mail: MitroT@sbcapcd.org.

ATTACHMENT:

A. Draft BARCT Analysis for Gas Turbines and Associated Duct Burners

ATTACHMENT A

Draft BARCT Analysis for Gas Turbines and
Associated Duct Burners

November 2, 2023

Santa Barbara County Air Pollution Control District
Community Advisory Council

260 San Antonio Road, Suite A
Santa Barbara, California 93110

**SANTA BARBARA COUNTY
AIR POLLUTION CONTROL DISTRICT**

**Assembly Bill 617 –
Draft BARCT Analysis for Gas Turbines and
Associated Duct Burners**

Date: October 20, 2023

Aeron Arlin Genet
Air Pollution Control Officer

Prepared By:
Tim Mitro
Air Quality Engineer

Main Office
260 N. San Antonio Road, Suite A
Santa Barbara, California 93110
Telephone (805) 979-8050
www.ourair.org

North County Office
301 E Cook St, Suite L
Santa Maria, CA 93454

Our Mission
*Our mission is to protect the people and the environment of
Santa Barbara County from the effects of air pollution.*

TABLE OF CONTENTS

	<u>Page</u>
1. BACKGROUND.....	1
1.1 Ozone and Health	1
1.2 The AB 617 BARCT Rule Development Schedule	1
1.3 ExxonMobil – Las Flores Canyon	2
2. BARCT ANALYSIS FOR GAS TURBINES AND ASSOCIATED DUCT BURNERS.....	4
2.1 Overview of Proposed Analysis	4
2.2 Analysis Applicability Determination	4
2.3 Requirement – NO _x Emission Limit	4
2.4 Requirement – Ammonia Slip Limit	7
2.5 Requirement – CO and ROC Emission Limits	7
2.6 Requirement – Monitoring Conditions and Averaging Times	8
3. IMPACTS OF THE BARCT ANALYSIS	9
3.1 Emission Impacts	9
3.2 Cost-Effectiveness	9
3.3 Implementation Timeline	11
4. REFERENCES	12

1. BACKGROUND

1.1 Ozone and Health

Ground level ozone is a secondary pollutant formed from photochemical reactions of the precursor pollutants oxides of nitrogen (NO_x) and reactive organic compounds (ROC) in the presence of heat and sunlight. Both short-term and long-term exposure to ozone can cause a number of health effects in broad segments of the population. Ozone can damage the respiratory system, causing inflammation and irritation, or symptoms such as coughing and wheezing. High levels of ozone are especially harmful for children, the elderly, and people with asthma or other respiratory problems. Ground-level ozone also impacts the economy by increasing hospital visits and medical expenses, loss of work time due to illness, and by damaging agricultural crops. Santa Barbara County is currently designated as nonattainment¹ for the state ozone standards.

1.2 The AB 617 BARCT Rule Development Schedule

Assembly Bill (AB) 617, enacted in July 2017, has many requirements to address the disproportionate impacts of air pollution in disadvantaged communities. One of the key components of AB 617 is to reduce air pollutant emissions from facilities that participate in the California Greenhouse Gas (GHG) Cap-and-Trade system. Cap-and-Trade is designed to limit GHG emissions and allows facilities to comply by either reducing GHG emissions at the source or by purchasing GHG emission allowances. Emissions of criteria pollutants and toxic air contaminants are often associated with large GHG-emitting sources, and these pollutants may impact local communities that are already experiencing a disproportionate burden from air pollution.

AB 617 helps alleviate the pollution burden near these communities by requiring each air district to adopt an expedited rule development schedule for Best Available Retrofit Control Technology (BARCT) by January 1, 2019. The District's AB 617 BARCT schedule was adopted at the December 2018 Board Hearing, and gas turbines were included on the list of equipment that needed to be evaluated for BARCT.² BARCT is an emission limitation that is based on the maximum degree of reduction achievable, taking into account environmental, energy, and economic impacts. To meet the BARCT emission limits, a facility may need to install new air pollution controls on their existing unit(s) or replace the unit(s) in part or in whole. The BARCT requirements apply to the following six facilities within the District boundaries since they were subject to the California Cap-and-Trade requirements on January 1, 2017:

- 1) ExxonMobil – Las Flores Canyon,
- 2) ExxonMobil – Pacific Offshore Pipeline Company (POPCO),
- 3) Pacific Coast Energy Company (PCEC) – Orcutt Hill,
- 4) Cat Canyon Resources, LLC – Cat Canyon West³,
- 5) Imerys Filtrations Minerals, Inc., and
- 6) Windset Farms.

¹ In January 2023, the California Air Resources Board held a [public hearing](#) to change Santa Barbara County's designation from "nonattainment" to "nonattainment-transitional." The change in designation is effective January 2024.

² Additional information on the AB 617 BARCT Rule Development Schedule is available on the District's website at www.ourair.org/community-air.

³ Facility was previously operated by ERG Operating Company.

The initial BARCT assessment in 2018 showed that it may be feasible and cost-effective to establish new BARCT standards for gas turbines. Out of the six facilities listed above, ExxonMobil’s Las Flores Canyon is the only facility that currently has a gas turbine permitted, and so this assessment is focused on the existing gas turbine. However, the BARCT assessment would also apply to any new gas turbine that is installed at the six industrial sources within Santa Barbara County.

1.3 ExxonMobil – Las Flores Canyon

The Las Flores Canyon Oil and Gas Plant (Las Flores Canyon) is a facility that is located approximately 20 miles west of Santa Barbara on the north side of Highway 101. The facility was originally permitted in 1987 to process crude oil and natural gas from Platforms Hondo, Harmony, and Heritage, which are located in federal waters off the California coast in the Santa Barbara Channel. The adjacent Pacific Offshore Pipeline Company (POPCO) Gas Plant processes the majority of the natural gas from the platforms while the Las Flores Canyon facility processes the crude oil/water/gas emulsion. Historically, Las Flores Canyon received the emulsion from the offshore platforms via a 20-inch pipeline, processed the emulsion, and transported the oil out of the facility through the Plains All American Pipeline. However, due to the 2015 rupture of the Plains All American Pipeline, the facility has been shut-in and maintained in a preserved state until a permitted means of transporting the oil is identified. The air quality operating permit for the facility remains current and active.

The equipment covered by this analysis is used in a 49 megawatt (MW) combined-cycle, cogeneration power plant, which consists of a General Electric gas turbine with a rated output of 39.35 MW and a steam turbine rated at 9.8 MW. The power plant generates electric power to supply both the onshore facilities and the offshore platforms. Heat from the gas turbine exhaust is recovered in a Heat Recovery Steam Generator (HRSG) to generate steam for the steam turbine and various on-site process heat requirements. The HRSG includes a Low-NOx Duct Burner that is used for supplemental heat to increase steam generation. The duct burner may also operate independent of the gas turbine to provide heat for facility operations. A flow diagram for these units is shown below in Figure 1.1.

Figure 1.1 – Combined-Cycle, Cogeneration Power Plant

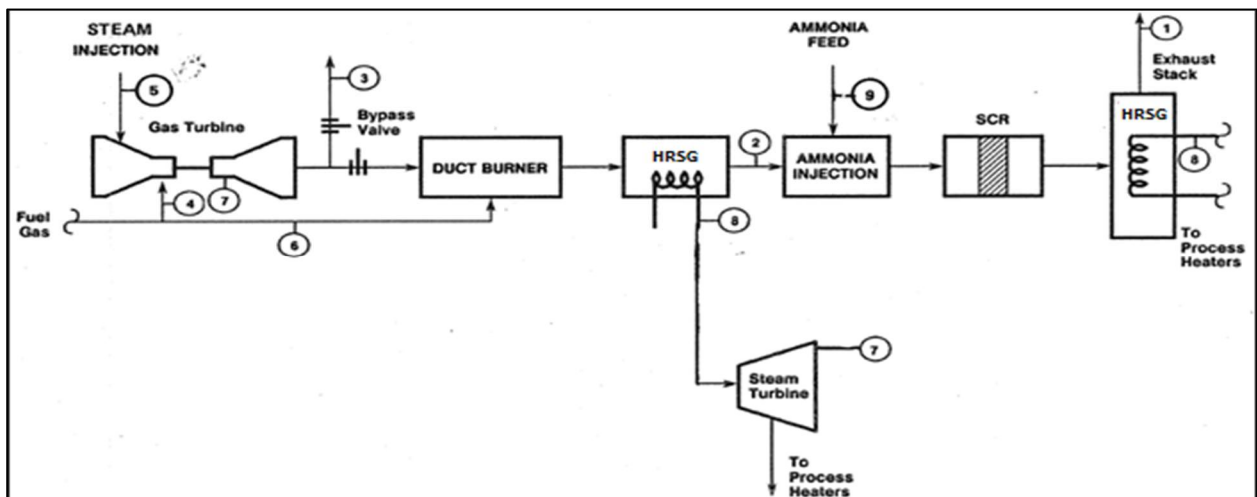

The maximum heat input to the gas turbine is 465 MMBtu/hr and the maximum heat input of the duct burner is 345 MMBtu/hr. The units are fueled with natural gas from the facility's Stripping Gas Treating Plant (SGTP) or from the local utility. When permitted in 1987, the gas turbine and duct burner were required to install Best Available Control Technology (BACT) and meet BACT emission standards for NO_x, Carbon Monoxide (CO), and ROC emissions. NO_x emissions are controlled through the use of steam injection in the gas turbine and Selective Catalytic Reduction (SCR) on the combined gas turbine and duct burner exhaust. The steam injection system is designed to achieve approximately 60 percent control for NO_x and the SCR reactor achieves upward of 80 percent control for NO_x. At the time of installation, BACT for CO and ROC was determined to be the use of pipeline quality gas and proper combustion techniques. The current permitted emission limits for the various operating modes, given in units of parts per million by volume (ppmv) and corrected to a 15% reference oxygen content¹, are shown below in Table 1.1.

Table 1.1. Permitted Emission Limits for the Combined-Cycle, Cogeneration Power Plant

<u>Operating Mode</u>	Maximum Heat Input (MMBtu/hr)	NO_x Limit (ppmv at 15% O₂)	CO Limit (ppmv at 15% O₂)
Tandem Mode (Turbine + Duct Burner)	605	7.4	11.6
Turbine Only Mode	465	8.1	9.6
Duct Burner Only Mode	345	8.1	132.4

¹ Throughout this document, all ppmv limits are referenced to a 15% oxygen content, unless otherwise stated.

2. BARCT ANALYSIS FOR GAS TURBINES AND ASSOCIATED DUCT BURNERS

2.1 Overview of Proposed Analysis

Although there are a variety of turbine configurations and fuel types, this BARCT analysis is focused on combined-cycle, cogeneration power plants using natural gas since this is the only turbine configuration currently being used at the AB 617 industrial sources within Santa Barbara County. This BARCT analysis does not address simple-cycle turbines or turbines fired on other fuels such as digester gas or landfill gas. District Staff reviewed the measures identified as BARCT in the California Air Resources Board's Technology Clearinghouse¹, and the following emission limits were identified as a means of reducing emissions in support of the BARCT provisions for AB 617:

- Combined-cycle turbines and associated duct burners shall meet the 2 ppmv NO_x standard; and
- The equipment shall not exceed an ammonia slip limit of 10 ppmv NH₃.

These standards are based on the recent BARCT determinations adopted by the South Coast Air Quality Management District (SCAQMD) under Rule 1134 and Ventura County Air Pollution Control District under Rule 74.23. All of the requirements to meet BARCT are described in further detail in their corresponding sections below, and an evaluation of the impacts of the new requirements are listed in Section 3 of this report.

2.2 Analysis Applicability Determination

As described in Section 1.2, the gas turbine and the duct burner are two separate combustion devices that can either work alone or in tandem to meet the facility's electrical and heating needs. At the time of initial permitting, the duct burner was considered a steam generator that was subject to District Rule 342 - *Boilers, Steam Generators, and Process Heaters rated at 5 MMBtu/hr and greater*. However, recent determinations from the United States Environmental Protection Agency (USEPA) group gas turbines and duct burners together since they often share the same SCR system and exhaust stack. Hence, District Rule 342 was amended in 2019 to exclude the duct burner, and all of the requirements listed in Section 2 will apply to both the gas turbine and the associated duct burner.

2.3 Requirement – NO_x Emission Limit

Based on our review of the California Air Resources Board (CARB) Technology Clearinghouse, the current BARCT standard for a combined-cycle power plant, which includes both the gas turbine and the duct burner, is 2.0 ppmv NO_x at 15% O₂. This BARCT standard is based on SCAQMD Rule 1134, as amended in 2019. The emission standard would apply to all three main operating modes for the Las Flores Canyon power plant [Tandem Mode, Turbine Only Mode, and Duct Burner Only Mode]. The emission standard would not apply to startup, shutdown, and maintenance operations.²

¹ <https://ww2.arb.ca.gov/current-air-district-rules>

² Maintenance and testing, as defined in the facility's permit, occur at loads no greater than 4 MW electrical output. At these low loads, the exhaust temperature will not be high enough for the SCR system to be effective.

The facility currently uses a steam injection system on the gas turbine to achieve NOx emission concentrations in the 40 to 60 ppmv range, and the SCR system reduces the emissions even further so that the final outlet concentration is in the 4 to 5 ppmv range. To achieve sub-2 ppmv NOx levels, the facility may need to perform one or more control strategies to reduce the equipment's NOx emissions. District staff identified three separate control strategies, and information on these strategies is given below:

- 1) Increase the steam injection rate into the gas turbine,
- 2) Retrofit the turbine system with a Dry-Low NOx combustor, and/or
- 3) Upgrade the existing SCR ammonia injection grid and reactor.

1) Steam Injection - Increase:

Steam injection has been used since the 1970s as a means of controlling NOx emissions from combustion turbines. Injecting steam into the flame area of the combustor provides a heat sink that lowers the combustion zone temperature and reduces thermal NOx formation. Steam injection can reduce NOx from the turbine by 60 percent or higher, with typical outlet concentrations in the 40 to 60 ppmv range. Steam injection is usually accompanied by an efficiency penalty (typically 2 to 3 percent) to generate the steam, but there is the benefit of increasing the electrical power output (typically 5 to 6 percent) due to the increased mass flowing through the turbine. Water used for steam injection must be demineralized to prevent deposits and corrosion from occurring in the turbine.

The gas turbine at Las Flores Canyon normally achieves NOx concentrations in the 40 to 60 ppmv range by using steam injection, but additional steam could be used to reduce the emissions even further. By increasing the steam injection rate, the gas turbine may achieve NOx concentrations near 25 ppmv, which is the lowest practical NOx level achievable with steam injection.¹ This strategy would lower the NOx emissions entering the SCR system.

2) Dry-Low NOx (DLN) Combustor - Retrofit:

DLN combustors are a newer technology that became commercially available for new installations and for retrofitted applications in the late 1990s. These units can achieve lower NOx levels in the gas turbine by minimizing localized hot spots that produce elevated combustion temperatures. They do this by pre-mixing the fuel with air prior to the combustion chamber, and then directing the fuel mixture to different zones under a staged combustion process. Using a DLN combustor reduces the gas turbine's NOx emissions by 80-95% percent, with typical concentrations in the 5 to 25 ppmv range. Hence, the DLN combustor has a higher control efficiency and a lower outlet NOx concentration compared to using steam injection.

If this control strategy is used, the existing combustor on the gas turbine would be replaced with a DLN combustor and the existing steam injection system would need to be removed. This strategy would lower the NOx emissions entering the SCR system.

¹ Per the 1992 CARB BARCT analysis and a 2022 Combustion Turbine NOx Control analysis performed for the EPA.

3) Existing SCR Reactor - Upgrade:

There are many parameters that affect SCR performance, such as the inlet NO_x values, the Ammonia Injection Grid (AIG) design, and the SCR catalyst type and volume. The current SCR system on the power plant achieves around 84-95% NO_x control, but additional improvements can be made to consistently achieve NO_x control efficiencies of 95% or greater.

One possible method to improve the existing SCR system is through the use of computer models to simulate the turbine exhaust gas flow with ammonia injection. SCR modeling can help determine if changes to the AIG are needed, such as resizing the AIG orifices or moving the AIG to a different location. AIG modifications can allow for a more uniform mixture of the exhaust gases and the ammonia, thereby enhancing the NO_x control efficiency and reducing the ammonia slip. An example of SCR modeling with poor ammonia distribution vs good ammonia distribution is shown below in Figure 2.1.

Figure 2.1 – SCR Modeling Examples

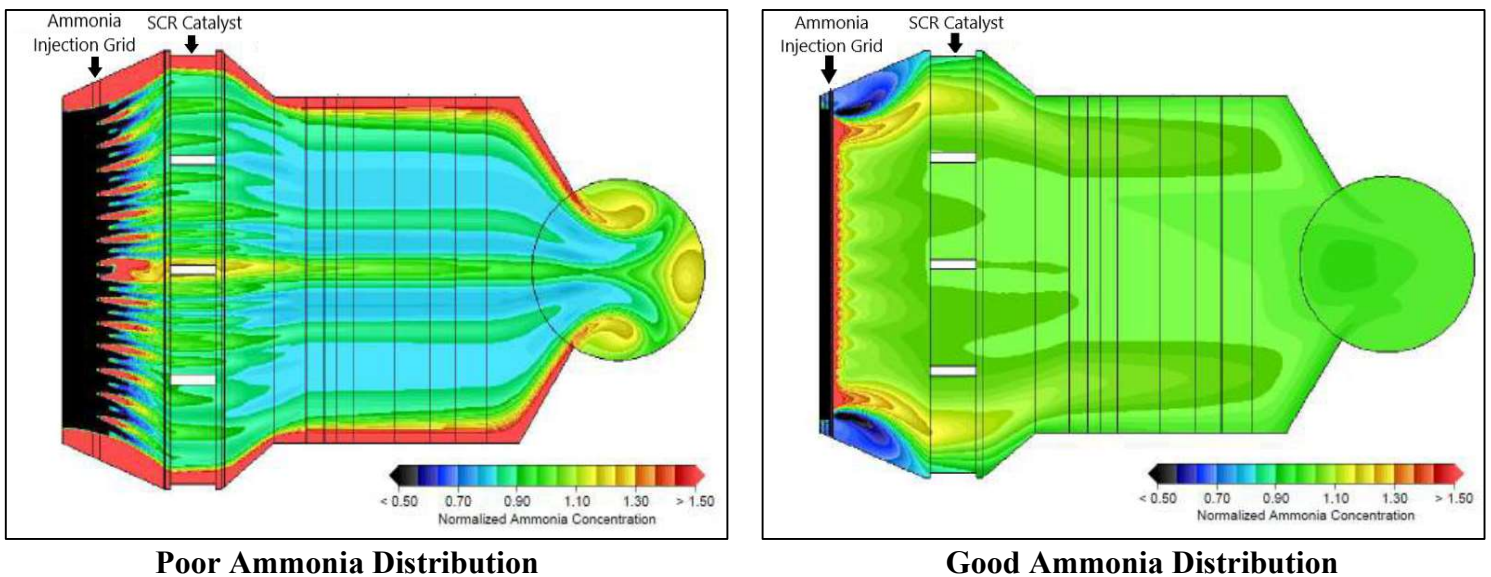

Another option to improve the efficiency of the SCR system is by adding more catalyst modules or by replacing the existing modules with catalysts that have a higher pore density. A 50% increase in the catalyst volume can help increase the NO_x control efficiency to 95% or greater. However, the additional catalyst volume may result in the need to install more structural supports to accommodate the reactor size and new air handling equipment to overcome the additional pressure drop. Physical constraints and space limitations at the facility could prevent the installation of additional catalyst volume.

Overall though, by upgrading one or more of the components of the existing SCR reactor, it is technically feasible that the combined-cycle power plant can achieve the 2 ppmv NO_x BARCT standard without any changes to the gas turbine or duct burner. It is anticipated that this control strategy will be used since it effectively controls the emissions from both combustion devices.

2.4 Requirement – Ammonia Slip Limit

Ammonia slip is an industry term for ammonia passing through the SCR unreacted. Ammonia slip occurs if excess ammonia is injected into the reactor, if temperatures are too low for the ammonia to react, or if the catalyst has degraded or is past its useful life. ExxonMobil's combined-cycle power plant has an ammonia slip permit limit of 20 ppmv at stack conditions, and the system was designed to not exceed 10 ppmv. Compliance with this condition is verified through annual sources tests using Bay Area Air Quality Management District's Test Method ST-1B, Ammonia Integrated Sampling (Adopted January 20, 1982).

Based on our review of the CARB Technology Clearinghouse, the current BARCT standard for ammonia slip is 10 ppmv NH₃ at 15% O₂. Although the ammonia injection rate may be increased to meet the NO_x BARCT requirement, the ammonia slip will be more tightly regulated with the 10 ppmv limit. The facility will need to ensure that the SCR system is optimally calibrated and that excess unreacted ammonia is not released into the atmosphere.

2.5 Requirement – CO and ROC Emission Limits

For turbine systems, high levels of CO and ROC emissions are typically a result of incomplete combustion. When gas turbines are operated at reduced loads, they do not achieve peak flame temperatures, yielding lower thermal efficiencies and higher CO and ROC emission rates. Also, excessive use of steam injection to control NO_x may in turn increase the CO and ROC emissions. For these situations, oxidation catalysts can be used on turbines to achieve upward of 80-90% control of the CO emissions and 40-50% control of the ROC emissions.

Based on our review of the CARB Technology Clearinghouse, the current BARCT standard for CO is 132.4 ppmv at 15% O₂ and no emission standard was identified for ROC. The CO standard¹ is used as a backstop because CO emissions above this threshold are indicative of improper combustion parameters (i.e., low-excess oxygen). The CO standard is also used as a surrogate for ROC emissions since both pollutants are caused by incomplete combustion.

During Tandem Mode, the Las Flores Canyon power plant is permitted to emit CO at sub-12 ppmv levels and ROC at sub-5 ppmv levels. These low CO and ROC levels are achieved through the use of proper combustion techniques and making sure that the equipment operates at a high load. Any adjustments made to the power plant to comply with the NO_x emission standards are not anticipated to increase the CO or ROC emission rate beyond the permitted emission levels. Furthermore, if the permitted CO or ROC emission levels are proposed to be increased, the power plant would be subject to BACT for those pollutants pursuant to Regulation VIII, New Source Review. Hence, the facility's existing permit limits for CO and ROC satisfy BARCT, and no additional equipment modifications are needed for these two pollutants.

¹ The CO standard of 132.4 ppmv at 15% O₂ is equivalent to 400 ppm CO at 3% O₂.

2.6 Requirement – Monitoring Conditions and Averaging Times

NOx and CO CEMS:

Continuous Emission Monitoring System (CEMS) are often installed on larger equipment units to provide accurate emission data and to ensure permit compliance. The Las Flores Canyon power plant is equipped with a CEMS to verify the continued compliance with the NOx and CO emission limits. The facility's permit specifies that the gas turbine and duct burner emission readings need to be based on 15-minute average data points. However, after reviewing the rules and technical assessments from other air districts, staff identified that many gas turbines need an averaging time of 3 hours to demonstrate compliance with the lower NOx limits. Since a 3-hour averaging time is longer than the facility's current 15-minute averaging time, a discussion on averaging times is given below.

Averaging times have a direct impact on the complexity, the cost, and the overall feasibility of an emission control system. To meet a NOx target of 2.0 ppmv, the emission control system for a gas turbine will generally have a targeted design rate around 1.8 ppmv NOx. This design rate incorporates a margin of safety so that if a fluctuation occurs and the NOx emissions increase for a short duration, there is a period of time for the operator to diagnose the problem and take the necessary corrective action(s) to return the system back to the 1.8 ppmv target. For turbine systems that are trying to meet the extremely low NOx emission target of 2 ppmv, a 15-minute window to rectify the issue and maintain average emissions below the standard is infeasible since the operating margin is so narrow (0.2 ppmv NOx).

Hence, to feasibly meet the 2 ppmv NOx limit, a 3-hour averaging time is needed. A longer averaging time does not increase the permitted emissions for the unit. Instead, the proposed averaging time minimizes short-term excursions and deviation reporting, especially if the operator can implement a solution within a short period of time. Furthermore, the CO averaging time may be increased up to the 3-hour mark to maintain consistent reporting parameters from the CEMS. These determinations are consistent with the CARB Guidance for the Permitting of Electrical Generation Technologies, as published in 2002.

Ammonia CEMS:

A newer technology that was investigated as part of this BARCT assessment is the use of an ammonia CEMS to verify continuous compliance with the ammonia slip limits. An ammonia CEMS uses a Tunable Diode Laser (TDL) to continuously measure the in-stack ammonia values. These units cost approximately \$60,000, but they can lead to better control of the ammonia injection rate and NOx emissions, as well as provide additional data on the SCR catalyst performance. Ammonia CEMS are expected to see more widespread use after additional protocols and certifications are adopted by other air districts, such as the South Coast AQMD or Bay Area AQMD.

For this BARCT assessment, an ammonia CEMS is not required due to the lack of approved protocols and certifications. If an acceptable protocol is reviewed and approved by the District in the future, the facility may elect to use an ammonia CEMS due to the benefits stated above. The ammonia CEMS would then be used for compliance in lieu of the annual ammonia source tests using Bay Area AQMD Test Method ST-1B.

3. IMPACTS OF THE BARCT ANALYSIS

3.1 Emission Impacts

The Las Flores Canyon power plant is not currently operating due to the rupture of the Plains All American Pipeline in 2015. However, if a new pipeline project or alternative product transportation method is approved, the facility would likely return to its normal production rates and resume operations for both the turbine and duct burner. For the purpose of this BARCT analysis, the representative conditions prior to the pipeline rupture are used to assess the potential emission impacts of the additional NOx control strategies. The estimated emission reduction amount is shown below in Table 3.1.

Table 3.1: Estimated Emission Reductions

<u>Equipment</u>	Representative NOx Emissions (tons/year)	Representative NOx Concentration (ppmv)	Final NOx Concentration (ppmv)	Actual NOx Reductions (tons/yr)
Cogeneration Power Plant (Turbine + Duct Burner)	32	4.5	1.8	19

Where:

- $\text{NOx Reductions} = \text{Representative NOx Emissions} * \left[1 - \frac{\text{Final NOx Conc.}}{\text{Representative NOx Conc.}} \right]$
- $19 \text{ tons/yr} = 32 \text{ tons/yr} * \left[1 - \frac{1.8 \text{ ppmv NOx}}{4.5 \text{ ppmv NOx}} \right]$
- Representative NOx Emissions and Representative NOx Concentration are based on the CEMS data for the unit from 2011 to 2014.
- Final NOx Concentration is the anticipated operating target to consistently comply with the 2 ppmv NOx standard.

District staff acknowledges that alternative methodologies could be used to estimate the emission reductions. However, the method prescribed above is used in this analysis because the CEMS data captures the historical and representative operating profile of the cogeneration power plant. Based on the equation above, the implementation of BARCT may reduce approximately 19 tons of NOx per year compared to the operational baseline.

3.2 Cost-Effectiveness

For cost-effectiveness calculations, the District uses the Levelized Cash Flow (LCF) method. In the LCF method, a capital recovery factor (CRF) is used to transform any capital costs into an equivalent annual cost. The CRF is necessary because the one-time capital expenditures reduce emissions over the entire duration of the project life. Hence, the CRF is a function of the real interest rate and equipment life.

District staff compiled the estimated costs for two separate scenarios based on data from both the South Coast AQMD and from ExxonMobil. These scenarios are: #1 - Upgrade the SCR reactor

and increase steam injection in the gas turbine, and #2 – Upgrade the SCR reactor and retrofit to a dry, low-NOx combustor. These two scenarios are anticipated to meet the 2 ppmv NOx standard for all three main operating modes [Tandem Mode, Turbine Only Mode, and Duct Burner Only Mode]. The estimated cost-effectiveness values for these scenarios are shown below in Table 3.2.

Table 3.2: Estimated Cost-Effectiveness for BARCT Analysis

BARCT Scenario	Description	Costs			Cost-Effectiveness	
		Capital Costs (million \$)	Annual O&M Cost (million \$/yr)	Annual Utility Cost (million \$/yr)	Annualized Cost (million \$)	Cost-Effectiveness (\$/ton)
#1	SCR upgrades + Increase Steam	\$3.6	\$0.25	\$0 to \$0.50	\$0.56 to \$1.06	\$30,000 to \$56,000
#2	SCR upgrades + DLN Retrofit	\$24.0	\$1.00	\$1.25	\$4.34	\$229,000

Where:

- Cost-Effectiveness = (Annualized Cost) / (Emission Reductions)
- Annualized Cost = (Capital Costs * CRF) + (Operation & Maintenance + Utility Costs)

- $$CRF = \frac{i * (1 + i)^n}{(1 + i)^n - 1} = \frac{0.06 * (1 + 0.06)^{20}}{(1 + 0.06)^{20} - 1} = 0.087$$

i = Real Interest Rate (6%)

n = Project Life (20 years)

Scenario #1 is the preferred scenario since the South Coast AQMD assessment showed that most turbine systems can achieve the 2 ppmv limit with just SCR modifications. If the turbine at Las Flores Canyon is having difficulty reaching 2 ppmv after the SCR changes, ExxonMobil could increase their steam injection usage in the gas turbine, which would have additional utility costs to pump, treat, and heat additional water for the steam injection. Scenario #1 presents a range in utility costs up to account for the increased steam injection rate.

Scenario #2 is an alternative scenario that incorporates the SCR upgrades as well as a Dry Low NOx combustor retrofit. Scenario #2 has a significant capital cost for the DLN retrofit and higher utility costs since the facility would lose out on the additional power output by removing the steam injection system, thereby requiring the facility to purchase additional electrical power from the utility. Scenario #2 is not expected to be chosen, but the costs are shown for informational purposes.

Overall, Scenario #1 shows that the project is considered cost-effective if the facility is operating similar to its operational baseline.

3.3 Implementation Timeline

ExxonMobil submitted two permit applications to comply with the BARCT analysis by incorporating new, enforceable conditions into its Permit to Operate (PTO). The Authority to Construct (ATC) permit will allow modifications to the turbine system to implement the BARCT requirements, and the PTO-Modification/Part 70 Minor Modification will incorporate the BARCT emission standards into the Part 70 operating permit for the Las Flores Canyon facility. The permit applications were deemed complete, and once issued, will have enforceable conditions that require the facility to comply with the BARCT conditions prior to the facility recommencing operations. Staff concludes that the enforceable permit conditions will effectively implement and satisfy the AB 617 mandate.

4. REFERENCES

- 1) South Coast Air Quality Management District – *Rule 1134, Emissions of Oxides of Nitrogen from Stationary Gas Turbines*, Amended April 5, 2019.
- 2) South Coast Air Quality Management District – *Rule 1109.1, Emissions of Oxides of Nitrogen from Petroleum Refineries and Related Operations*, Amended November 5, 2021.
- 3) Fossil Energy Research Corporation – *South Coast Air Quality Management District Rule 1109.1 Study Final Report*, November 2020.
- 4) Norton Engineering – *Proposed Rule 1109.1 NOx BARCT Review*, December 2020.
- 5) Ventura County Air Pollution Control District – *Rule 74.23, Stationary Gas Turbines*, Amended November 12, 2019.
- 6) Bay Area Air Quality Management District – *Regulation 9-9, Nitrogen Oxides from Stationary Gas Turbines*, Amended December 6, 2006.
- 7) San Joaquin Valley Air Pollution Control District – *Rule 4703, Stationary Gas Turbines*, Amended April 25, 2002.
- 8) California Air Resources Board – *Guidance For the Permitting of Electrical Generation Technologies*, July 2002.
- 9) California Air Resources Board – *Determination of Reasonably Available Control Technology and Best Available Retrofit Control Technology for the Control of Oxides of Nitrogen from Stationary Gas Turbines*, May 1992.
- 10) Sargent & Lundy – *Combustion Turbine NOx Control Technologies Memo*, Project No. 13527-002 (January 2022).
- 11) U.S. Environmental Protection Agency – *Standards of Performance for Stationary Gas Turbines – Proposed Rule*, 70 Fed. Reg. 8314 (February 18, 2005).
- 12) U.S. Environmental Protection Agency – *Standards of Performance for Stationary Gas Turbines – Final Rule*, 71 Fed. Reg. 38482 (July 6, 2006).
- 13) U.S. Environmental Protection Agency – *Standards of Performance for Stationary Gas Turbines – Proposed Rule*, 77 Fed. Reg. 52554 (August 29, 2012).
- 14) U.S. Environmental Protection Agency – *Alternative Control Techniques Document - NOx Emissions from Stationary Gas Turbines*, EPA-453/R-93-007 (January 1993).
- 15) Santa Barbara County Air Pollution Control District – *Assembly Bill 617 Best Available Retrofit Control Technology Rule Development Schedule*, Adopted December 20, 2018.



MEMORANDUM

DATE: October 20, 2023

TO: Community Advisory Council (CAC) Members

FROM: Alex Economou, (805) 979-8333, AJE@sbcapcd.org

SUBJECT: Background Information and Briefing on Rule 210, Fees

At the November 2, 2023 CAC meeting, District staff will present information regarding the history of District Rule 210 - Fees and an overview of the proposed amendments to the rule. This agenda item will be informational only (i.e., no formal CAC recommendation will be sought). This agenda item will help prepare the CAC members for upcoming meeting and discussions pertaining to the amendments to Rule 210. For this rule proceeding, staff anticipates conducting a virtual public workshop, returning to the CAC for a formal recommendation on the rule amendments, and conducting two public hearings for the Board of Directors to consider adopting the amendments to the rule.

Background

District Rule 210, Fees, is intended to recover District costs associated with programs related to permitted stationary sources and for other District activities mandated by state and/or federal regulations. The rule includes administrative and technical evaluation fees for the initial installation of equipment that discharges air contaminants, and on-going fees to inspect and verify that the operation continues to comply with all applicable requirements. The District is proposing amendments to Rule 210 and the associated fee schedules in an effort to improve cost recovery from the District's stationary source program, align permit fees with individual stationary source program costs, and to provide for a clear and consistent fee structure for the regulated community.

Permit fees in Rule 210 have not been increased in more than 32 years, except for the annual Consumer Price Index (CPI) adjustment, which has failed to keep up with increased operating costs. In the past 32 years, the District has broadened its funding base so that permit fees are only one of several funding sources. In Fiscal Year 2018-19, facing ongoing decreased oil and gas activity and associated revenue implications, the District implemented a fiscally conservative agency reorganization to reduce costs and enhance efficiency measures. In 2023, the District prepared a Long-Range Fiscal Strategy (Strategy) by analyzing historical revenue and expenditures and detailed projections over five years. Developing the Strategy also involved conducting a Cost Recovery and Fee Analysis (Fee Study), which found that the District is achieving only 47% cost recovery for various fee-based programs. Those fiscal stability challenges, combined with workload management and staff retention needs, require additional measures to provide the District with a long-term mechanism to stay fiscally sound. The District

presented the Long-Range Fiscal Strategy [package](#) to our Board of Directors in October 2023; the Board received and filed the [presentation](#) and will consider the aforementioned measures at future meetings.

If there are questions or concerns that you would like to discuss prior to the meeting, please contact me or Tim Mitro at (805) 979-8329 / e-mail: MitroT@sbcapcd.org.