

Central Coast Wine Services

Central Coast Wine Services

2717 Aviation Way, Suite 101

Santa Maria, CA 93455

(805) 318-6500 FAX (805) 928-5629

April 26, 2017

Engineering and Compliance Division
Santa Barbara County Air Pollution Control District
260 North San Antonio Road Suite A
Santa Barbara CA 93110



Subject: Central Coast Wine Services (FID 11042; SSID 10834)
Authority to Construct Application

To whom it may concern:

Enclosed please find an Authority to Construct application (Form APCD 01) to modify the allowable uses for the 400-series tanks in PTO 14696. This application also seeks authority to construct a barrel room capable of holding up to 2,500 oak barrels.

In addition to Form APCD-01, also enclosed are, a detailed process description, tank and barrel room drawings, Forms APCD-02 and technical specifications for the control devices, and the application filing fee of \$385.00.

Confidentiality

According to California Government Code Section 6254.7, Central Coast Wine Services (CCWS) has designated certain parts of this application as confidential trade secrets. CCWS has prepared this submittal in accordance with Santa Barbara County Air Pollution Control District Policies and Procedures Policy No. 6100.020.2016, Handling of Confidential Information. CCWS understands that as specified in this policy, "trade secrets are defined as (but are not limited to) any formula, plan, pattern, process, tool, mechanism, compound, procedure, production data, or compilation of information which is not patented, which is known only to certain individuals within a commercial concern who are using it to fabricate, produce, or compound an article of trade or a service having commercial value and which gives its user an opportunity to obtain a business advantage over competitors who do not know or use it."

Please let us know if there are any questions or comments.

Sincerely,

A handwritten signature in black ink, appearing to read "Richard D. Mather".

Richard Mather
Business Manager
Central Coast Wine Services

Enclosure



General Permit Application Form -01

Santa Barbara County Air Pollution Control District
260 N. San Antonio Road, Suite A
Santa Barbara, CA 93110-1315

1. APPLICATION TYPE (check all that apply):

- | | |
|--|---|
| <input checked="" type="checkbox"/> Authority to Construct (ATC) | <input type="checkbox"/> Transfer of Owner/Operator (use Form -01T) |
| <input type="checkbox"/> Permit to Operate (PTO) | <input type="checkbox"/> Emission Reduction Credits |
| <input type="checkbox"/> ATC Modification | <input type="checkbox"/> Increase in Production Rate or Throughput |
| <input type="checkbox"/> PTO Modification | <input type="checkbox"/> Decrease in Production Rate or Throughput |
| <input type="checkbox"/> Other (Specify) _____ | |

Previous ATC/PTO Number (if known) _____ PTO 14696

Yes No Are Title 5 Minor Modification Forms Attached? (this applies to Title 5 sources only and applies to all application types except ATCs and Emission Reduction Credits). Complete Title 5 Form -1302 A1/A2, B, and M. Complete Title 5 Form -1302 C1/C2, D1/D2, E1/E2, F1/F2, G1/G2 as appropriate. <http://www.ourair.org/wp-content/uploads/t5-forms.pdf>

Mail the completed application to the APCD's Engineering Division at the address listed above.

2. FILING FEE:

A \$385 application filing fee must be included with each application. The application filing fee is COLA-adjusted every July 1st. Please ensure you are remitting the correct current fee (the current fee schedule is available on the APCD's webpage at: <http://www.ourair.org/district-fees>). This filing fee will not be refunded or applied to any subsequent application. Payment may also be made by credit card by using the Credit Card Authorization Form at the end of this application.

3. IS YOUR PROJECT'S PROPERTY BOUNDARY LOCATED OR PROPOSED TO BE LOCATED WITHIN 1,000 FEET FROM THE OUTER BOUNDARY OF A SCHOOL? If yes and the project results in an emission increase, submit a completed Form -03 (*School Summary Form*). <http://www.ourair.org/wp-content/uploads/apcd-03.pdf> Yes No

If yes, provide name of school(s): _____
 Address of school(s): _____
 City: _____ Zip Code: _____

4. DOES YOUR APPLICATION CONTAIN CONFIDENTIAL INFORMATION? Yes No

If yes, please submit with a redacted duplicate application which shall be a public document. In order to be protected from disclosure to the public, all information claimed as confidential shall be submitted in accordance with APCD Policy & Procedure 6100-020 (*Handling of Confidential Information*): <http://www.ourair.org/wp-content/uploads/6100-020.pdf>, and meet the criteria of CA Govt Code Sec 6254.7. Failure to follow required procedures for submitting confidential information, or to declare it as confidential at the time of application, shall be deemed a waiver by the applicant of the right to protect such information from public disclosure. *Note: Part 70 permit applications may contain confidential information in accordance with the above procedures, however, the content of the permit documents must be public (no redactions).*

| FOR APCD USE ONLY | | | | DATE STAMP |
|-------------------|-----------------------------|-----------------|-----------|------------|
| FID | 11042 | Permit No. | ATC 15044 | |
| Project Name | Central Coast Wine Services | | | |
| Filing Fee | \$385.00 | 202.E? YES / NO | | |

5. COMPANY/CONTACT INFORMATION:

| | | | | | |
|-------------------|----------------|---|----------------|-------------------------|--------------------------------|
| Owner Info | | <input type="checkbox"/> Yes <input checked="" type="checkbox"/> No | | Use as Billing Contact? | |
| Company Name | | Central Coast Wine Warehouse, LLC | | | |
| Doing Business As | | Central Coast Wine Services | | | |
| Contact Name | | Richard Mather | Position/Title | Business Manager | |
| Mailing Address | | 2717 Aviation Way, Suite 101 | | | |
| City: | Santa Maria | State | CA | Zip | 93455 |
| Telephone | (805) 450-8219 | Fax | (805) 928-5629 | Email | rmather@thornhillcompanies.com |

| | | | | | |
|----------------------|----------------|---|----------------|-------------------------|--------------------------------|
| Operator Info | | <input checked="" type="checkbox"/> Yes <input type="checkbox"/> No | | Use as Billing Contact? | |
| Company Name | | Central Coast Wine Warehouse, LLC | | | |
| Doing Business As | | Central Coast Wine Services | | | |
| Contact Name | | Richard Mather | Position/Title | Business Manager | |
| Mailing Address | | 2717 Aviation Way, Suite 101 | | | |
| City: | Santa Maria | State | CA | Zip | 93455 |
| Telephone | (805) 450-8219 | Fax | (805) 928-5629 | Email | rmather@thornhillcompanies.com |

| | | | | | |
|-------------------------------|---------------|---|----------------|--------------------------|---------------------|
| Authorized Agent Info* | | <input type="checkbox"/> Yes <input checked="" type="checkbox"/> No | | Use as Billing Contact? | |
| Company Name | | M. F. Strange & Associates, Inc. | | | |
| Doing Business As | | | | | |
| Contact Name | | Marianne Strange | Position/Title | Environmental Consultant | |
| Mailing Address | | P. O. Box 1484 | | | |
| City: | Santa Barbara | State | CA | Zip | 93102 |
| Telephone | 805-564-6590 | Fax | 805-564-8007 | Email | mstrange@mfsair.com |

*Use this section if the application is not submitted by the owner/operator. Complete APCD Form -01A (<http://www.ourair.org/wp-content/uploads/apcd-01a.pdf>). Owner/Operator information above is still required.

| | |
|--|---|
| SEND PERMITTING CORRESPONDENCE TO (check all that apply): | |
| <input type="checkbox"/> Owner | <input checked="" type="checkbox"/> Operator |
| <input checked="" type="checkbox"/> Authorized Agent | <input type="checkbox"/> Other (attach mailing information) |

6. GENERAL NATURE OF BUSINESS OR AGENCY:

Custom Crush Winery – Wine Storage

7. EQUIPMENT LOCATION (Address):

Specify the street address of the proposed or actual equipment location. If the location does not have a designated address, please specify the location by cross streets, or lease name, UTM coordinates, or township, range, and section.

Equipment Address: 2717 Aviation Way, Suite 101

City: Santa Maria State: CA Zip Code: 93455

Work Site Phone: (805) 450-8219

[X] Incorporated (within city limits) [] Unincorporated (outside city limits) [] Used at Various Locations

Assessors Parcel No(s): 111-29-21

8. PROJECT DESCRIPTION:

(Describe the equipment to be constructed, modified and/or operated or the desired change in the existing permit. Attach a separate page if needed):

Central Coast Wine Services (CCWS) seeks to modify the operational restrictions in PTO 14696 on the 400-series tanks to allow fermentation of red or white wines in any of these tanks. Additionally, CCWS seeks to install a barrel room with a capacity for 2500 oak barrels. These barrels will be used for fermentation and storage.

See Attached Process Description for details of the application request.

9. DO YOU REQUIRE A LAND USE PERMIT OR OTHER LEAD AGENCY PERMIT FOR THE PROJECT DESCRIBED IN THIS APPLICATION? [] Yes [X] No

A. If yes, please provide the following information

Table with 4 columns: Agency Name, Permit #, Phone #, Permit Date. All cells are empty.

* The lead agency is the public agency that has the principal discretionary authority to approve a project. The lead agency is responsible for determining whether the project will have a significant effect on the environment and determines what environmental review and environmental document will be necessary. The lead agency will normally be a city or county planning agency or similar, rather than the Air Pollution Control District.

B. If yes, has the lead agency permit application been deemed complete and is a copy of their completeness letter attached?

[] Yes [] No [X] N/A

Please note that the APCD will not deem your application complete until the lead agency application is deemed complete.

C. If the lead agency permit application has not been deemed complete, please explain.

Empty rectangular box for explanation.

D. A copy of the final lead agency permit or other discretionary approval by the lead agency may be requested by the APCD as part of our completeness review process.

10. PROJECT STATUS

- A. Date of Equipment Installation: Upon issuance of IPAP or ATC
- B. Have you been issued a Notice to Comply (NTC) or Notice of Violation (NOV) for not obtaining a permit for this equipment/modification *and/or* have you installed this equipment without the required APCD permit(s)? If yes, the application filing is double per Rule 210. []Yes [X]No
- C. Is this application being submitted due to the loss of a Rule 202 exemption? []Yes [X]No
- D. Will this project be constructed in multiple phases? If yes, attach a separate description of the nature and extend of each project phase, including the associated timing, equipment and emissions. []Yes [X]No
- E. Is this application also for a change of owner/operator? If yes, please also include a completed APCD Form -01T. []Yes [X]No

11. APPLICANT/PREPARER STATEMENT:

The person who prepares the application also must sign the permit application. The preparer may be an employee of the owner/operator or an authorized agent (contractor/consultant) working on behalf of the owner/operator (an *Authorized Agent Form -01A* is required).

I certify pursuant to H&SC Section 42303.5 that all information contained herein and information submitted with this application is true and correct.

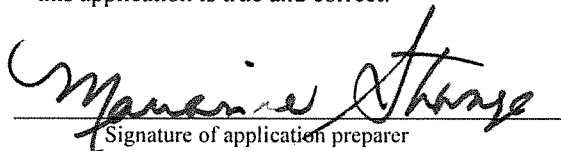

 Signature of application preparer

4/26/17

 Date

Marianne F. Strange

 Print name of application preparer

M. F. Strange & Associates

 Employer name

12. APPLICATION CHECKLIST (*check all that apply*)

- [X] Application Filing Fee (Fee = \$385.00. The application filing fee is COLA adjusted every July 1st. Please ensure you are remitting the current fee.) As a convenience to applicants, the APCD will accept credit card payments. If you wish to use this payment option, please complete the attached *Credit Card Authorization Form* and submit it with your application.
- [] Existing permitted sources may request that the filing fee be deducted from their current reimbursable deposits by checking this box. Please deduct the filing fee from my existing reimbursement account.
- [] Form -01T (*Transfer of Owner/Operator*) attached if this application also addresses a change in owner and/or operator status from what is listed on the current permit. <http://www.ourair.org/wp-content/uploads/apcd-01t.pdf>
- [] Form -03 (*School Summary Form*) attached if the project's property boundary is within 1,000 feet of the outer boundary of a school (k-12) and the project results in an emissions increase. <http://www.ourair.org/wp-content/uploads/apcd-03.pdf>
- [X] Information required by the APCD for processing the application as identified in APCD Rule 204 (*Applications*), the APCD's *General APCD Information Requirements List* (<http://www.sbcapcd.org/eng/dl/other/gen-info.pdf>), and/or one of the APCD's *Process/Equipment Summary Forms* (<http://www.ourair.org/permit-applications>).
- [X] Form -01A (*Authorized Agent Form*) attached if this application was prepared by and/or if correspondence is requested to be sent to an Agent Authorized (e.g., contractor or consultant). This form must accompany each application. <http://www.ourair.org/wp-content/uploads/apcd-01a.pdf>
- [X] Confidential Information submitted according to APCD Policy & Procedure 6100-020. (*Failure to follow Policy and Procedure 6100-020 is a waiver of right to claim information as confidential.*)

13. NOTICE OF CERTIFICATION:

All applicants must complete the following Notice of Certification. This certification must be signed by the Authorized Company Representative representing the owner/operator. Signatures by Authorized Agents will not be accepted.

NOTICE of CERTIFICATION

I, Richard Mather, am employed by or represent
Type or Print Name of Authorized Company Representative

Central Coast Wine Services

Type or Print Name of Business, Corporation, Company, Individual, or Agency

(hereinafter referred to as the applicant), and certify pursuant to H&SC Section 42303.5 that all information contained herein and information submitted with this application is true and correct and the equipment listed herein complies or can be expected to comply with said rules and regulations when operated in the manner and under the circumstances proposed. If the project fees are required to be funded by the cost reimbursement basis, as the responsible person, I agree that I will pay the Santa Barbara County Air Pollution Control District the actual recorded cost, plus administrative cost, incurred by the APCD in the processing of the application within 30 days of the billing date. If I withdraw my application, I further understand that I shall inform the APCD in writing and I will be charged for all costs incurred through closure of the APCD files on the project.

For applications submitted for Authority to Construct, modifications to existing Authority to Construct, and Authority to Construct/Permit to Operate permits, I hereby certify that all major stationary sources in the state and all stationary sources in the air basin which are owned or operated by the applicant, or by an entity controlling, controlled by, or under common control with the applicant, are in compliance, or are on approved schedule for compliance with all applicable emission limitations and standards under the Clean Air Act (42 USC 7401 *et seq.*) and all applicable emission limitations and standards which are part of the State Implementation Plan approved by the Environmental Protection Agency.

Completed By: Richard Mather Title: Business Manager

Date: 04/26/2017 Phone: (805) 450-8219

Signature of Authorized Company Representative: 

**PLEASE NOTE THAT FAILURE TO COMPLETELY PROVIDE ALL REQUIRED INFORMATION OR FEES WILL
RESULT IN YOUR APPLICATION BEING RETURNED OR DEEMED INCOMPLETE.**



Print Form

Authorized Agent Form Application Form -01A

Santa Barbara County Air Pollution Control District
260 N. San Antonio Road, Suite A
Santa Barbara, CA 93110-1315

I hereby designate
(agent's name - print)

of
(agent's business name - print)

to serve as the Authorized Agent for my company:
(applicant or permitted company's name - print)

at
(facility name(s) - print)

in dealing with the Santa Barbara County Air Pollution Control District (APCD) in matters regarding (check as appropriate):

- Permitting
- Billing
- Air Toxics/HRA
- Source Testing
- Inspections and Permit Compliance
- All of the above

Other (state purpose):

This Designation included written correspondence, telephone discussions and meetings and shall remain in effect until it is suspended in writing by my company or the following date: whichever is earlier.

As a designated Responsible Official, I hereby authorize the above mentioned agent to represent my company in the matters identified above:

| | |
|------------------|--------------------------------|
| Name (print) | Richard Mather |
| Title | Business Manager |
| Phone | (805) 450-8219 |
| Email | rmather@thornhillcompanies.com |
| Address | 2717 Aviation Way, Suite 101 |
| City, State, Zip | Santa Maria, CA 93455 |
| Signature | |

CCWS
400-Series Tank Modification & Barrel Room Addition

ATC Application – Process Description

Central Coast Wine Services (CCWS) is seeking to modify the allowable uses of the existing 400-series tanks in PTO 14696. Ten (10) of these tanks are currently permitted for wine storage and fermentation of white wines. The remaining thirty (30) tanks are permitted for wine storage only. CCWS is seeking to modify these operational limitations through this Authority to Construct (ATC) application. CCWS is requesting to have all forty (40) of the 400-series tanks available for red or white wine fermentation as well as wine storage. Table 1 below summarizes the current and proposed uses for the 400-series tanks.

Table 1 – 400-Series Tank Details

| APCD Device ID | Tank No.'s | Qty | Current Use | Proposed Use | Individual Tank Capacity, gal | Net Capacity, gal |
|----------------|-------------------------------------|-----|-------------------------------|--------------|-------------------------------|-------------------|
| 388059 | 401-405 & 411-415 | 10 | F&S (White Fermentation Only) | F&S | 14980 | 149800 |
| 388060 | 421, 423-424, 452 | 4 | S | F&S | 14980 | 59920 |
| 388061 | 422, 431-434, 441-444, 451, 453-454 | 12 | S | F&S | 20736 | 248832 |
| 388062 | 461-465, 471-475, 481-484 | 14 | S | F&S | 7527 | 105378 |

In addition to these operational changes to the 400-series tanks, CCWS is requesting authority to construct barrel storage and fermentation in the existing room immediately north of the tank room. (See Attachment A: Drawings Sheets B3 & B4). This barrel room will be capable of containing up to 2500 oak barrels. These barrels will be used for both fermentation and storage.

Emissions Control

Per Condition 12 of PTO 14696, this ATC represents an increase in facility emissions; therefore the requirements of Best Available Control Technology (BACT) as described in Rule 802.D (New Source Review) are applicable to this project.

The District is in the process of registering the EcoPAS and NohBell control technologies as BACT in the CARB database and has given instructions that CCWS should consider these technologies as BACT for this project. Accordingly, CCWS agrees that one of these controls will be in place any time fermentation is occurring in a 400-series tank. Additionally, CCWS agrees to apply emission's control to the legacy tanks in the facility during all fermentation.

As per the District's guidance on emission controls on the 400-series tanks and legacy fermentation tanks, CCWS requests that the ROC emission limit for the entire facility be increased to 240 pounds per day: Facility Emission Offset requirement threshold. CCWS understands that a project emission limitation of 240 pounds per day may not be allowable due to the results of an Air Quality Impact Analysis (AQIA) per Rule 802.G. Therefore, a project emission limit between 120 pounds per day (AQIA threshold) and 240 pounds per day could be agreed upon per the results of the District's AQIA analysis.

BACT Control Efficiency

Each vendor of the emissions control devices has provided CCWS with individual performance guarantees for their technologies. It is CCWS' understanding that the District will be conditioning this permit with similar recordkeeping requirements as the existing facility permit (PTO 14696). Additionally, the BACT efficiency of these technologies will be based upon the combined capture rates on a rolling thirty-day efficiency as measured during the Source Compliance Demonstration Period (SCDP). The rolling thirty-day efficiencies will then be used to establish the permitted BACT control efficiency for this project.

CCWS would like to request that the permitted BACT efficiency be based upon the lowest of the thirty-day efficiencies measured during SCDP minus five percent. Experience has shown that the efficiencies of these technologies are both very dependent upon the fermentation stage of the must in the tanks that are being controlled. There are also variables within each season that could affect the efficiency of these technologies across any thirty day period: variability in the Brix numbers of the fruit being delivered (affected by weather), variability in the profiles of fruit deliveries (affected by the weather), and the variety of wines being fermented during any thirty day period (affected by the market). CCWS is confident that any permitted BACT control efficiency established using the lowest SCDP control efficiency minus 5% will be achievable in future years.

EcoPAS Technology

Attachment B contains a District Form 02, EcoPAS literature, and a performance guarantee for the EcoPAS control technology. Notable in this performance guarantee are:

- The performance guarantee requires a minimum and maximum vapor flow rate to the control device (50 to 300 CFM)
- The performance guarantee is not valid when the Brix reduction is less than 25% (e.g. first 25% of fermentation).
- The performance guarantee is not valid when the tank man-ways are open. (tank man-ways are frequently required to be open during the fermentation process).

NohBell's NoMoVo Technology

Attachment C contains a District Form 02, NohBell literature, and a performance guarantee for the NoMoVo control technology. Notable in this performance guarantee are:

- The variability of the absorption efficiency across a single fermentation cycle.
- NohBell is confident that, taking into account the stated variable nature of their technology, and the unknown performance of the capture manifold, this device can still obtain a 67% overall capture and absorption efficiency. NohBell engineering has a solid understanding of winemaking operations at CCWS and has incorporated that understanding into their estimation of the impacts of the intermittent nature of the capture manifold into their performance guarantee. However, this understanding still requires validation.

Attachment A

Facility Drawings

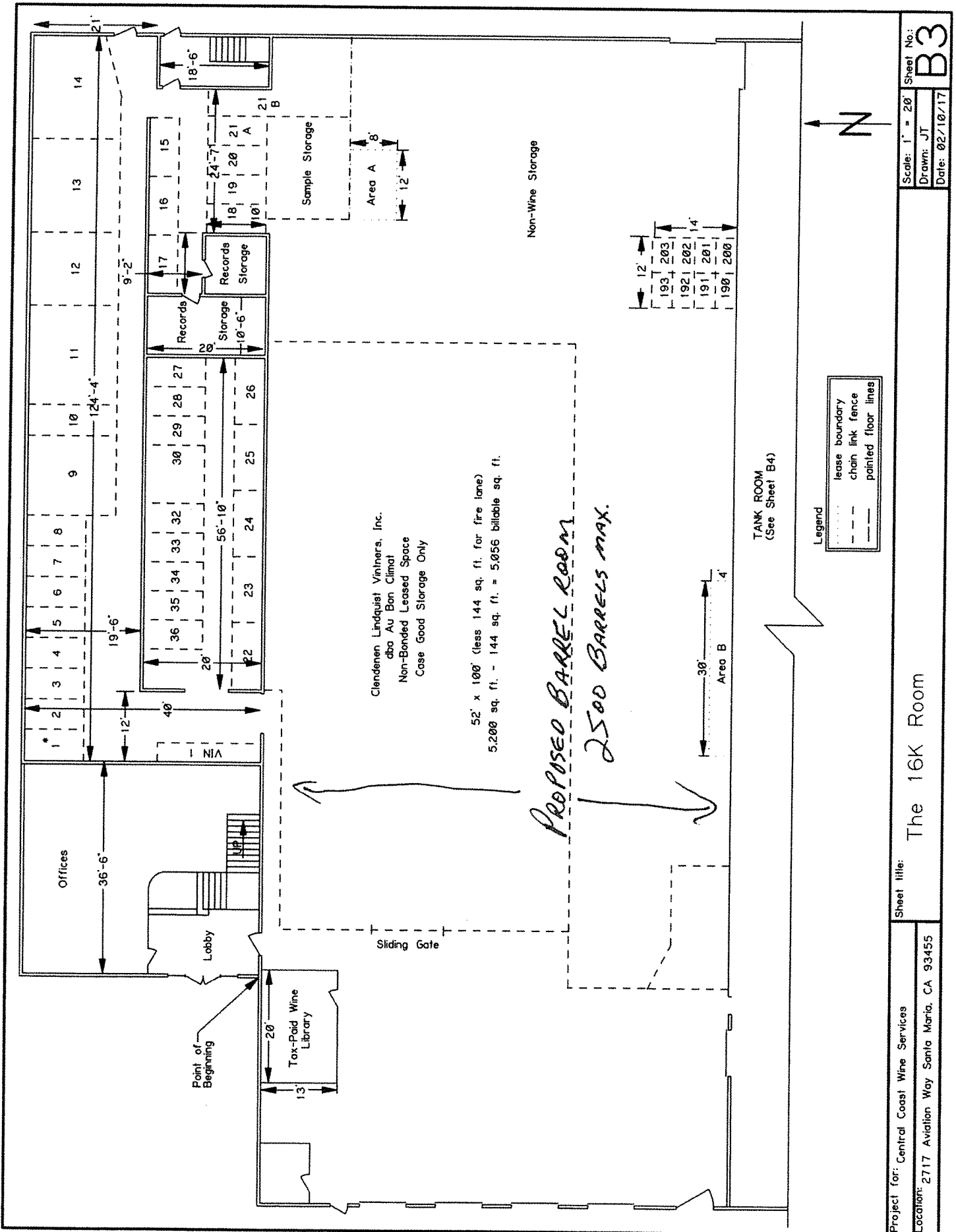

Project for: Central Coast Wine Services
 Location: 2717 Aviation Way Santa Maria, CA 93455

Sheet title: The 16K Room

Scale: 1" = 20'
 Drawn: JT
 Date: 02/10/17
 Sheet No.: B3

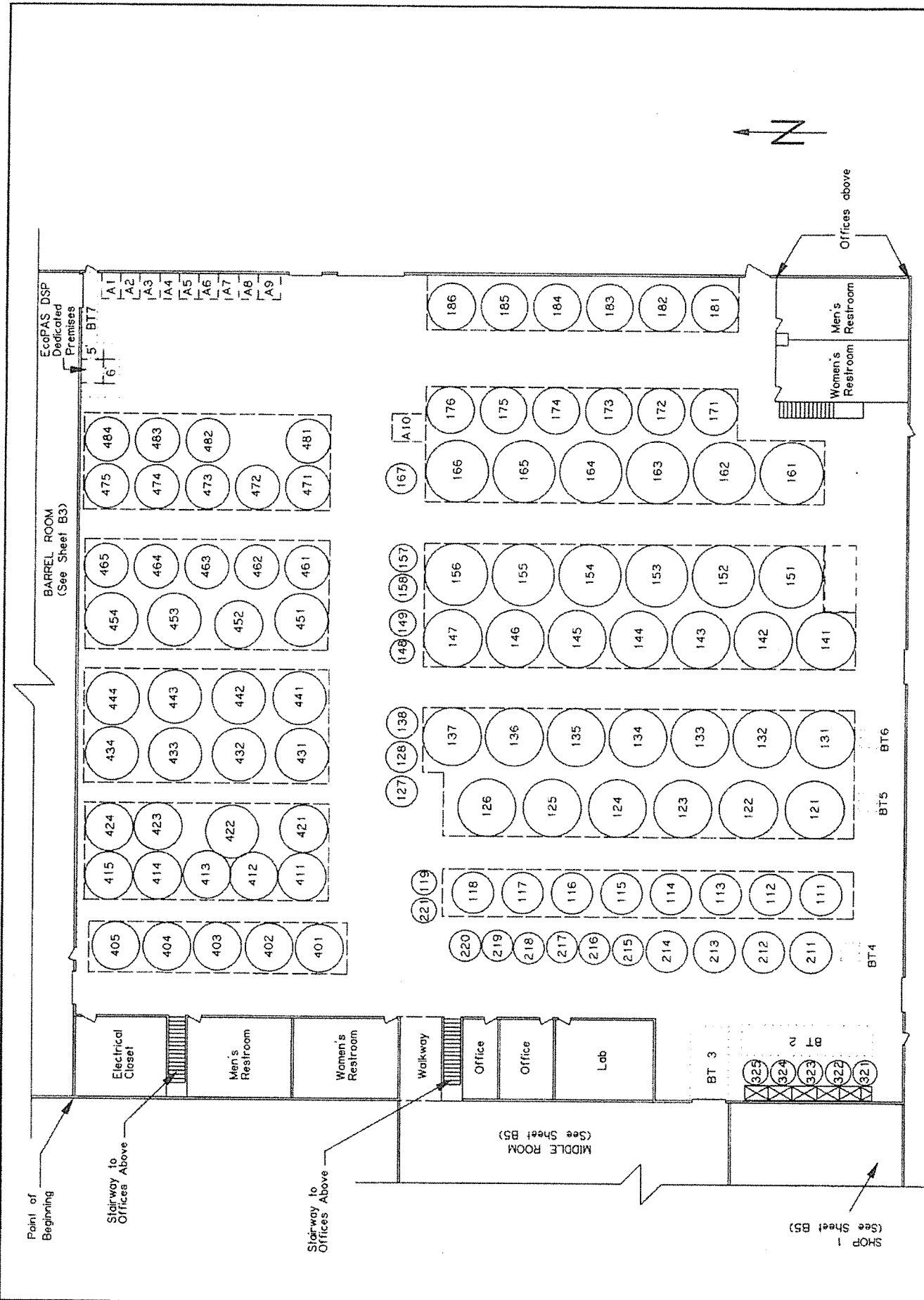

Attachment B

EcoPAS Technology



**Santa Barbara County
Air Pollution Control District**

Our Vision: Clean Air

BACT ANALYSIS SUMMARY FORM

This form must be submitted by all applicants when Best Available Control Technology ("BACT") is required, except for small sources that utilize BACT as listed on the APCD's *Small Source BACT List*, for which case this form is not required. This form supplements APCD Regulation II and applicable APCD application guideline documents. Please fill in all sections of this form completely. Also, fill in a separate form for each emissions unit subject to BACT (multiple units with the same BACT may use only one form). Use additional sheets as necessary.

COMPANY NAME: Central Coast Wine Services (CCWS) DATE: April 20, 2017

FACILITY/SOURCE NAME: Central Coast Wine Services – Santa Maria Winery

1. POLLUTANT(S) SUBJECT TO BACT REVIEW: ROC (Ethanol)

2. EMISSION UNIT(S)/PROCESS(ES) SUBJECT TO BACT REVIEW: Closed Tank Fermentation

3. BACT SUMMARY:

Technology: Vapor Condensation – EcoPAS

Performance Standard: To be Determined – EcoPAS has provided CCWS with a performance guarantee of 67%. However this control efficiency has not been validated. Limitations of the capture system were not taken into consideration. Only with proper validation can a real control efficiency be assigned to this combination of vapor capture and ethanol extraction from the vapor stream.

Performance as described is only valid when determined by the existing mass-balance process.

4. BACT SELECTION PROCESS DISCUSSION: On a separate sheet of paper, describe the justification for the selected control technology as BACT. Include the following in your description: documentation of technical infeasibility which would preclude the use of a more effective control technology; operating conditions at which the maximum daily and hourly emissions will be generated (baseline parameters); maximum daily and hourly emissions at the baseline conditions and the basis of how the emission rates were estimated; calculations, emission data, and/or other information to determine control effectiveness of each potential control technology; and emission limits expressed both in terms of an emissions cap (e.g., pounds per day) and in terms which ensure compliance at any operating capacity (e.g., pounds per million British thermal units, or parts per million by volume).

5. BACT EFFECTIVENESS: Discuss how BACT will be effective over all operating ranges.

This technology is not effective over all operating ranges. These devices operate passively and require a minimum vapor flow before performance is guaranteed. Additionally, performance is not guaranteed during the first 25% of Brix reduction.

6. BACT DURING NON-STANDARD OPERATIONS: Discuss whether the proposed BACT is achievable during non-standard operations and if not, what BACT is for those operations.

BACT will not be achievable during non-standard operations. During non-standard operations the control efficiency will be zero. Non-Standard operations are any time the tank man-way is opened to perform normal winemaking operations (e.g. visual inspections or tank pump-overs).

7. OPERATING CONSTRAINTS: Identify all process variables for which operating limits need to be set in order to ensure compliance with the selected BACT standards.

To Be Determined

8. MONITORING BACT: Describe, in detail, how the selected BACT is to be monitored for its emission reduction effectiveness.

Until a source test protocol is promulgated by the US EPA, as has been indicated, effectiveness will be determined by mass balance calculations using existing recordkeeping protocols.

9. ALTERNATE BASIC EQUIPMENT: Discuss whether alternate basic equipment (e.g., electric motors in lieu of IC engines) can be applied to this application.

No alternatives are known

10. Yes No Will this be a multi-year and/or multi-phase project?

11. Yes No Are all referenced documents attached?

12. Yes No If PSD BACT is triggered, was a detailed Top-Down BACT Analysis prepared and submitted with the application? Please be aware that the applicant is responsible for providing the APCD with this analysis.



Performance Guarantee

Proposal #17102

Date: April 14, 2017

1. Guarantee

- a. EcoPAS guarantees that the Combined Capture & Control Efficiency of the PAS-100 system operating at CCWS will be 67% or higher, provided that all Performance Conditions are met.

2. Definitions

- a. "Capture Efficiency"
 - i. The percentage of air emission that is collected and routed to the control equipment is referred to as capture efficiency.
- b. "Control Efficiency"
 - i. The percentage of air pollutant removed from the exhaust/venting stream by the control device.
- c. "Combined Capture & Control Efficiency"
 - i. Overall VOC removal percentage is derived from the multiplication of *capture efficiency (%)* by *control efficiency (%)*.
- d. "Performance Conditions"
 - i. The conditions under which this guarantee is valid
- e. "Performance Test"
 - i. The test method agreed upon to determine if Combined Capture & Control Efficiency % is achieved.

3. Performance Conditions

- a. Primary Conditions
 - i. Flow
 1. Vapor flow (CO₂, water vapor, and ethanol vapor) shall be greater than 50 CFM and less than 300 CFM
 - ii. Fermentation stage
 1. The average stage of fermentation for all tanks connected and fermenting at a given time shall be between 25% and 100% Brix reduction

- b. Secondary Conditions (generally required to meet primary conditions)
 - i. Physical
 1. All manway covers and lids shall mate properly to reduce vapor leaks at the perimeter of lids. (One or more of the lids last season were warped and did not seal effectively during fermentation.)
 2. All manway gaskets must be supple and compressible. Over time the neoprene gaskets lose flexibility and allow leakage at the manway lids.
 3. Manifold connections must be tight and capable of operating without leaks while under slight backpressure. (<0.2 psi)
 4. Adequate glycol flow (5gpm) and incoming temperature (33-36dF) must be delivered to the PAS.
 5. Foam-overs shall be avoided by maintenance of adequate tank headspace (>15% tank capacity). If lower headspace percentages are anticipated, a foam-over preventer will need to be installed at each manway valve assembly.
 - ii. Operational
 1. Cellar crew must connect hoses to manifold and direct vapor exhaust flow into manifold system to PAS
 2. Manway lids and gaskets shall be flat (not folded over) and centered to avoid leaks that will reduce capture efficiency. This should be checked each time a lid is opened and reset.
 3. When lid is lifted for additions, pumprovers or other winemaking purpose hose valve must be set to bypass. Duration of lid opening should be recorded and once lid is closed following operation, the valve should be reset to collect.
 4. When manway lid is reclosed during active fermentation, valve should be returned to the "collect" position and the manway lid rechecked to ensure it is centered and that there is no perceptible vapor leak around the perimeter of the lid
 5. A running log of condensate volume collected and proofing is to be maintained by CCWS laboratory staff.

4. Performance Tests

- a. The Performance Test shall be a comparison of calculated emissions to actual captured VOCs.
- b. Emissions shall be calculated using an agreed-upon formula, based on ARB emissions factors. Required inputs for this calculation shall include, at a

minimum, connected fermenting tank fill volumes, daily brix reduction, and fermentation temperatures.

- c. Captured VOCs shall be calculated by multiplying daily collection volume by ethanol concentration %
- d. Captured VOCs, divided by calculated emissions, shall yield a CC&CE %.
- e. The test period will be a minimum of 3 sequential days, all in full compliance with the Performance Conditions, and EcoPAS shall have the right to approve and witness Performance Tests.
- f. If the system does not satisfy Performance Guarantee as determined by the Performance Test, then EcoPAS shall, at our option, either:
 - i. Repair, replace, or modify the system until it satisfies the Performance Guarantee, or
 - ii. Pay CCWS as liquidated damages in full satisfaction of all claims arising out of failure to meet Performance Guarantee, and amount equal to all payments made to us under this contract.



PAS Operator Manual

Version 2015-1.0



Innovation Science & Engineering Solutions for the Wine Industry

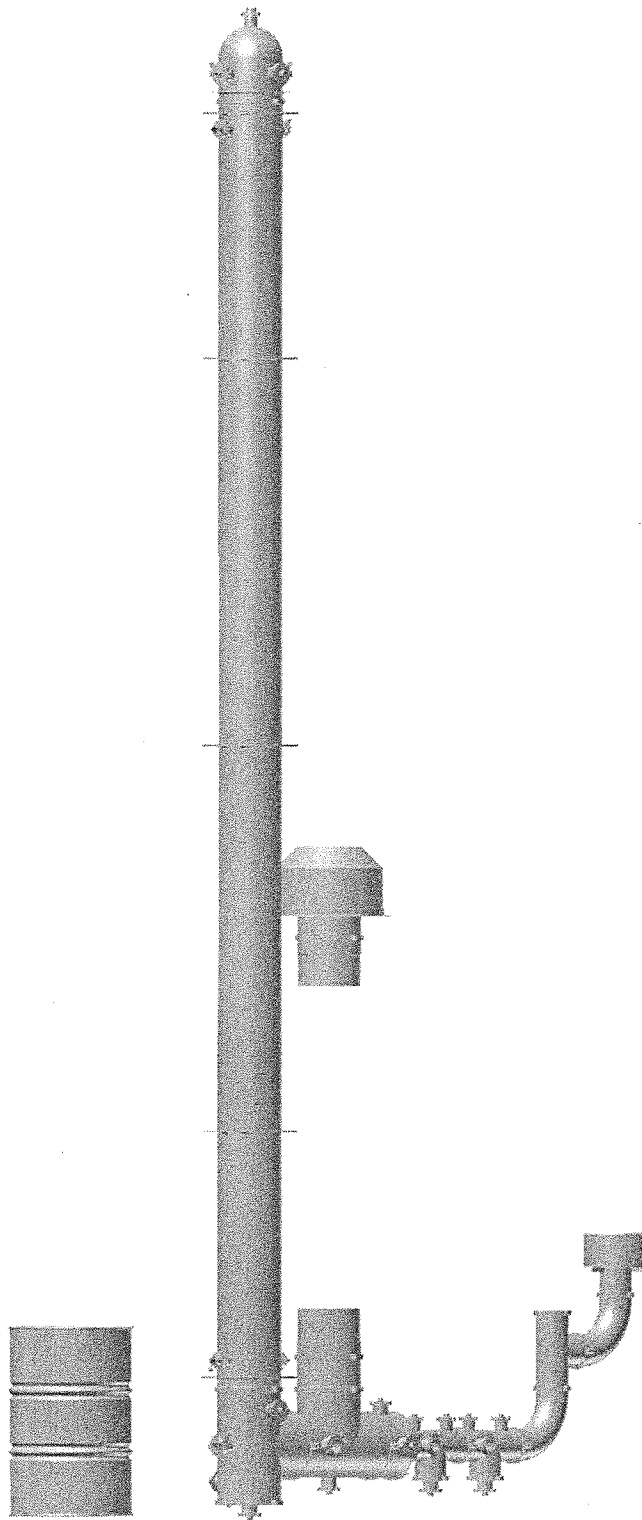

EcoPAS, LLC was established in 2007 to provide innovative solutions for the wine industry. We take pride in our integrity, expertise, and service to our customers. Our mission is to bring scientific and technological innovations to the wine industry, create the highest quality and best-value products, and do no harm to winemaking or the environment.

EcoPAS Products:

- ❖ FermentTracker
- ❖ Ferment Inspect - software
- ❖ Passive Alcohol System (PAS)

Symbol Legend:



Caution



Warning



Explosion Hazard



Stop and observe carefully before proceeding



Shock Hazard



Asphyxiation Hazard

Table of Contents

| <u>Chapter</u> | <u>Page</u> |
|------------------------------------|-------------|
| 1. General Information | 5 - 7 |
| 2. Installation | 8 - 9 |
| 3. Operation | 10 - 11 |
| 4. Maintenance | 12 |
| 5. Troubleshooting and Spare Parts | 13 |
| 6. Service | 14 |
| 7. Replacement Parts | 15 |
| Appendix A – Glossary | 16 - 17 |
| Appendix B – Drawings | 18 - 27 |

Chapter 1 - General Information

1. Function

The Passive Alcohol System (PAS) device is intended for fugitive ethanol capture, commonly emitted during wine fermentation. The primary function of the device is to reduce the ozone impact created by the entrained ethanol (EtOH) with the carbon dioxide (CO₂) which is released during primary wine fermentation. A secondary function on the device is utilization of the captured ethanol-water mixture for other purposes, such as: increase the alcohol in the host wine; a spirit beverage; pharmaceutical; cosmetic; food; fuel; and, other applications that utilize a food-grade ethanol.

2. Purpose

PAS is designed as a food-grade application device which is compatible with wine production and use with standard winery equipment, such as fermentation tanks, house glycol system, and tri-clamp connections.

3. Use

The device is engineered to operate at less than 5"-H₂O pressure. The piping system, manifolds, and hoses must not contain any traps or liquid retention locations, other than at the liquid capture tanks designed for that purpose. All components are designed to be self-draining without use of mechanical, electrical, or other means of drainage. No fans, pumps, or other power-activated air-handling devices are required for the operation of the PAS device as intended.

4. Specifications

Prior to installation of the PAS in any configuration or application, it is recommended that the attachment/support method be reviewed by a State Licensed Professional Structural Engineer. Review of the seismic forces, wind forces, PAS unit weight (including glycol), and moment on the tank/structure supporting the PAS unit should be considered in addition to other forces and field conditions. When charged with refrigerant (such as glycol), the PAS device total dead weight can exceed 1,200-lbs (>545-Kg).

Depending on the configuration, the **minimum** suggested installation clearance is:

Horizontal Mount (such as: ground or platform): 4' h x 30' w x 4' d

Vertical Mount (such as: tank, wall, or column): 30' h* x 10' w x 4' d

**Allowance for drain hoses and capture tanks not included in height*

Note: dimensions are approximate and depending on obstacles and varying field conditions, smaller or greater clearances could be required.

A valved chilled glycol supply and return connection with hoses is required. Ideally, the glycol supply should be between 34°-F (1°-C) to 40°-F (4°-C), although other temperatures may be utilized effectively as explained in the "Installation" section of this

manual. Depending on the PAS orientation, distance from the supply and return piping and fittings, the required minimum glycol system pressure will vary. It is recommended that a review by a Licensed Professional Mechanical Engineer or other professional familiar with the system determine the required minimum delivery pressure and total loss created by the PAS and connections. Depending on the required flow volume and unit orientation, the pressure loss through the PAS unit could vary between 0.04-psi to 0.18-psi (1" H₂O to 5" H₂O).

The glycol supply line to the PAS device should be the same pipe size or larger than the device connection. The glycol return line from the PAS device should be the at least one pipe size larger than the device connection. It is recommended that a Licensed Professional Mechanical Engineer determine the supply and return piping size or contact EcoPAS for assistance.

5. Warnings



To prevent possible injury and damage to the fermentation tank and PAS device, never operate the PAS device with a greater must volume, higher daily Brix reduction, and higher must temperature than intended for safe operation range of the device. Use the EcoPAS calculator (available upon request) or the formula below (based upon the Lynn Williams formula for CO₂ potential release from wine fermentation); note: typically, 190 g/L is a more accurate factor for most commercial wine fermentation rather than the 240 g/L utilized for personnel Life-Safety calculations.

Lynn Williams Formula for Potential CO₂ Release (Life-Safety Factor@ ≈27-Bx start):

$$\frac{\text{Liters CO}_2}{\text{Liter juice}} = \left[\frac{22.4 \text{ Liters}}{\text{mole CO}_2} \times \left(\frac{240 \text{ grams}}{\text{Liter}} \times \frac{1 \text{ mole}_{\text{sugar}}}{180 \text{ grams}} \times \frac{2 \text{ moles CO}_2}{1 \text{ mole}_{\text{sugar}}} \right) \times \frac{273.2 + T_{\text{must } ^\circ\text{C}}}{273.2} \right]$$

Suggested Formula for Potential CO₂ Release to the PAS device:

$$\frac{\text{Liters CO}_2}{\text{Liter juice}} = \left[\frac{22.4 \text{ Liters}}{\text{mole CO}_2} \times \left(\frac{190 \text{ grams}}{\text{Liter}} \times \frac{1 \text{ mole}_{\text{sugar}}}{180 \text{ grams}} \times \frac{2 \text{ moles CO}_2}{1 \text{ mole}_{\text{sugar}}} \right) \times \frac{273.2 + T_{\text{must } ^\circ\text{C}}}{273.2} \right]$$



Always utilize EcoPAS supplied components, gaskets, and recommended parts to insure proper and safe operation.



It is recommended that direct ventilation of the CO₂ gas be provided to atmosphere to prevent possible injury or death from lack of safe levels of oxygen and exposure to CO₂.

6. Safety

All components should be thoroughly sanitized prior to initial use, as well as, prior to and following each subsequent seasonal use. The PAS components are manufactured from materials that are commonly used within a winery and the winemaking process. Standard wine industry sanitation methods and procedures should be sufficient to clean and sanitize the PAS components; EcoPAS recommends following 3A guidelines for proper sanitation.

The PAS will be subjected to higher levels of alcohol than found in most sanitizing solution; minimal or no sanitizing should be required between use with the same or other tanks.

SAFETY CHECKS:



- Never operate the PAS device without verifying that the glycol supply and return lines are connected, the valves fully open, and that glycol is flowing through the device.
- Never operate the PAS without the appropriately sized capture tanks connected and the drain valves fully open.
- To avoid over-pressurizing the fermentation tank and PAS, verify that the Tank Manufacturers maximum suggested pressure is not exceeded.
- Verify the EcoPAS Pressure Release Valve (PRV) and the tank PVR are installed properly, functioning as designed and intended, and, free of debris, sticky coating, and residual sugars.
- Avoid glycol supply temperature below 34°F (1°C), as freezing of the condenser tubes may occur typically before a Brix reduction of **at least 1.75°-Bx** below the initial starting Brix. Glycol temperatures below 20°F (-6°C) are not recommended at any time.



- Avoid glycol temperature above 40°F (4°C) to insure maximum capture efficiency.
- Insure that the PAS device is vented to atmosphere and exhausts in to a safe area.
- Maintains a safe clearance from air-handling equipment or intake vents; consider down-wash of the CO₂ (heavier than air) from the PAS exhaust vent.



- Prior to each operation:
 - Insure that all valves are in proper operating position.
 - Insure that there is sufficient capacity in the capture tanks for at least 150% of the calculated volume of captured liquid.

Chapter 2 – Installation

1. Safety

All components should be sanitized prior to initial use. Standard wine industry sanitary component cleaning and sanitation methods and procedures should be sufficient to clean and sanitize the PAS components; EcoPAS recommends following standard 3A guidelines for proper sanitation.

Prior to installing, connecting, or supporting the PAS device on any structure or building component, the installation and anchoring method should be reviewed by a Licensed Professional Structural Engineer.



WARNING: NEVER EXCEED the PAS rated capacity for process gases. Ferment tank pressure should **NEVER exceed 6" H₂O and ideally never greater than 5" H₂O**. Always calculate the total potential CO₂ release and system pressure prior to each operation to verify safe and effective operating ranges. See Formula in Section 1.5.



CONDITIONS AND INSTALLATIONS VARY: CHECK WITH AN APPROPRIATE LICENSED PROFESSIONAL ENGINEER IF BONDING AND GROUNDING MAY BE REQUIRED FOR SAFE OPERATION OF THE PAS UNIT AND CAPTURE STORAGE TANKS TO PREVENT POSSIBLE FIRE OR EXPLOSION.



VERIFY IF REGULATIONS SUCH AS: NFPA 30 "FLAMMABLE AND COMBUSTIBLE LIQUIDS CODE", NFPA 91 "STANDARD FOR EXHAUST SYSTEMS FOR AIR CONVEYING OF VAPORS, GASES, MISTS, AND NONCOMBUSTIBLE PARTICULATE SOLIDS", AND SIMILAR REGULATIONS ARE APPLICABLE TO YOUR INSTALLATION, APPLICATION, AND USE.



VERIFY IF PERMITS ARE REQUIRED FOR THE DEVICE, INSTALLATION, AND OPERATION FROM THE AIR REGULATORY AGENCY HAVING JURISDICTION.



VERIFY IF PERMITS ARE REQUIRED FOR THE DEVICE, INSTALLATION, AND OPERATION FROM LOCAL BUILDING REGULATORY AGENCY HAVING JURISDICTION, SUCH AS: BUILDING, MECHANICAL, FIRE, AND OTHER DEPARTMENTS/AGENCIES THAT MAY REQUIRE PERMITS.



Lightening Protection: It is recommended that lightning protection, in accordance with NFPA 780, be provided to prevent potential explosion and fire in case of a lightening or static discharge through the system.



CO₂ Asphyxiation: Carbon dioxide (CO₂) naturally released from the fermentation process is vented through the PAS unit. Insure that that the PAS vent placement is in a safe location with consideration of downdrafts, wind, and physical barriers which could direct the carbon dioxide into worker zones. Carbon dioxide is a colorless, odorless, non-flammable and slightly acidic liquefied gas. CO₂ is heavier than air and soluble in water.

2. Mounting

a. PAS Unit

- i. The PAS may be installed and operate as intended in either a horizontal, vertical, or inclined orientation. Different connecting components are required for each configuration; verify you have the correct components for the orientation desired or contact EcoPAS for assistance.

PAS mounting suggestions:

1. Fermentation tank
2. Post or column
3. Rack or support frame at ground level
4. Wall
5. Cart

b. Hoses

- i. Avoid condensate traps; position the PAS unit lower than the ferment tank connection and avoid increasing elevation with the hose between the tank connection and the PAS unit to insure proper drainage of condensate.
- ii. Provide allowance in the hose length for open/swing of the access port/lid/door to the fermentation tank, if the connection port is mounted to the ferment tank hatch port/lid/door.

3. Manifold

- a. The ferment tank connection port should be the same diameter or larger than the EcoPAS recommended hose size, except for ganged fermentations.

4. Process Hose

- a. If the captured ethanol is intended for beverage, pharmaceutical, or other food grade applications, than Teflon™ or PTFE lined hoses are recommended to avoid imparting a taste from the hose material.
- b. Hoses should be manufactured from materials and methods compatible with and compliant for food grade application and exposure to ethanol.

5. Pressure-Vacuum Relief (PVR) - [fermentation tank]

- a. For proper and efficient operation of the PAS unit, it is recommended that a PVR be installed that will release at pressures greater than 6" H₂O, ideally greater.

Chapter 3 – Operation

1. First Time Use



The PAS was design to last for many ferment seasons and function as a valuable tool to the winemaker. Utilize ONLY EcoPAS components or authorized components, as damage, improper operation, or explosion could occur. All components must be cleaned and sterilized prior to use. Standard winery sanitation and component sterilization practices should be sufficient for the PAS parts.

Read the manual carefully for information on the proper use and maintenance of the PAS device and components.

2. Sanitizing

- a. Utilize standard industry sanitizing procedures for wine fermentation tanks to sanitize the PAS and components, or:
 - i. Thoroughly wash all components and flush the condenser tubes with cold water to remove any solids.
 - ii. Utilize an industry standard sanitizing solution, such as one tablespoon sodium metabisulphite per gallon water, to flush and sanitize all components interior and exterior surfaces.
 - iii. Flush all surfaces with hot water **at least** three times. A high-pressure hose is best, as it will help blast any remaining particulate and organisms from the walls.
 - iv. Rinse with cold water and let dry.
 - v. Utilize standard industry practices for sealing and protecting the unit after sanitizing, if the unit will be inactive (see Section 3.4).

3. Activation



- a. Ideally, the PAS device should be operated at 34°-F (1°-C) minimum to 40°-F (4°-C) maximum coolant temperature to prevent potential freezing of captured moisture within the condenser columns and maximize capture efficiency. While the device can operate at lower temperatures, operating below 34°-F (1°-C) could cause freezing of the captured water vapor and plug the condenser tubes; operating above 40°-F (4°-C) could reduce the capture efficiency. Extreme caution should be used if operating with a coolant (glycol) temperature below 34°-F (1°-C), as plugged condenser tubes could cause over-pressurization of the fermentation tank above a safe level and release of the ferment vapor through the PVR or the EcoPAS high-pressure PRV. If operating with a glycol temperature below 34°-F (1°-C), it is recommended that the device not be connected to the fermentation tank until at least a Brix reduction of 1.75°-Bx or greater. Typically, the alcohol level with the released CO₂ will be sufficient to lower the freezing point of any water vapor when the Brix reduction of the must has decreased 1.75°-Bx from the initial starting Brix.
- b. The PAS device may be operated effectively in the horizontal, vertical, or inclined positions. The device is designed to operate effectively in both interior and exterior applications, including exposure to direct sunlight. To reduce energy demand, an indoor or shaded location is preferred.

- c. The PAS inlet manifold may be connected to the fermentation tank with either rigid tubing (such as T304/L or T316/L tubing) or flexible hose (ideally with a PTFE lining if the captured liquid will be utilized to fortify the wine or for other applications to prevent tainting the liquid with a potential plastic taste)

- 4. Deactivation
 - a. Sanitize all components, as recommended Section 3.2 above, and seal all open ports with blank plates after the unit is thoroughly dry.

- 5. Annual servicing prior to first seasonal use
 - a. Sanitize the PAS unit and components prior to initial use per Section 3.2.
 - b. Test the PRV's and PVR for proper release pressure.
 - c. Replace any warped, damaged, or worn gaskets.

Chapter 4 – Maintenance

The EcoPAS PAS unit and components are durable products and should exceed the longevity of the wine fermentation tank. Since there are no motors, pumps, electrical components, or fuel operated components, the only expected wear items are the springs (EcoPAS Pressure Relief Valve), hoses, and the PTFE Tri-Clamp gaskets.

1. Check hoses and piping periodically for “traps” that may contain liquid in the supply line.
 - a. Exception: Traps are **required** in the drainage hoses to prevent release of EtOH vapors during low flow conditions.
 - b. Hoses should be checked periodically for issues such as wear, abrasion, kinks, and pin holes.

2. Operation outdoors
 - a. Exterior installation locations will be subjected to ambient temperatures (possibly varying from 0°-F to 120°-F), ultraviolet rays, infrared rays, wind, rain, snow, and other atmospheric conditions that could affect the performance of the PAS unit and system. While the unit and system should perform as intended under these conditions, variation of the refrigerant temperature or flow could be required.

3. Cleaning and Sanitizing
 - a. Follow the instructions in Chapter 3.2.

Chapter 5 – Troubleshooting

1. Reduced Flow
 - a) Check for a blockage in the system, such as:
 - i) Closed, partially opened, or blocked valves
 - ii) Frozen condenser tubes
 - iii) Blank plate not removed
 - b) Stuck or inactive ferment
 - c) Hose or system component loose or disconnected

2. Whistling or unusual noise
 - a) Excessive flow
 - b) Ferment activity higher than expected
 - c) Restriction, such as:
 - i) Frozen condenser tubes
 - ii) Particulate in hose, tubing, or condenser tubes
 - iii) Foreign matter in hose or PAS unit
 - iv) Blockage in system

3. Lower than normal capture
 - a) Leakage in system
 - i) Loose connections
 - ii) Open by-pass valve
 - iii) PVR leakage
 - iv) PRV leakage
 - b) Blockage in system
 - c) No or low fermentation activity
 - d) Low must temperature
 - e) Sluggish ferment
 - f) System coolant (glycol) temperature above 40°-F

4. System pressure greater than 6" H₂O
 - a) Excessive flow
 - b) Ferment activity higher than expected
 - c) Restriction
 - i) Frozen condenser tubes
 - ii) Particulate in condenser tubes
 - iii) Foreign matter in hose/unit
 - iv) Blockage, check:
 - (1) Condenser
 - (2) Exhaust port

Chapter 6 – Service

If you should require assistance, guidance, spare parts, or repair of the PAS or any component, please contact us at:

EcoPAS, LLC
3579 East Foothill Blvd. #251
Pasadena, CA 91107-3119
626-539-5850
info@eco-pas.com email
www.eco-pas.com website

Prior to contacting EcoPAS, please have the following information available:

- 1) Serial number
- 2) Tank Identification Number
- 3) Tank Volume Capacity
- 4) Ferment Information:
 - a) Must Gallons/Tons
 - i) Varietal
 - ii) Cap (yes/no)
 - iii) Starting Brix
 - iv) Current Brix
 - v) Starting must temp
 - vi) Current must temp
 - vii) Glycol temperature at the PAS supply line
 - viii) Glycol temperature at the PAS return line
- 5) Additional questions you may be asked when contacting EcoPAS for assistance:
 - a) When did the issue first occur?
 - i) Is it Intermittent?
 - b) Are the ports plugged or blocked?
 - c) Have you followed all the recommended component and system checks?

Chapter 7 – Replacement Parts

- 1) In the unlikely event that replacement parts are required, please contact EcoPAS for the proper component to insure continued safe and effective operation.

- 2) The Tri-clamp gaskets (utilize only PTFE gaskets) and clamps are available from suppliers such as:
 - i. Austenitex
(302) 504-3100
www.austenitex.com

 - ii. G.W. Kent
(734) 572-1300
www.gwkent.com/winery.html

 - iii. McMaster-Carr
(562) 692-5911
www.mcmaster.com

Appendix A – Glossary and Reference

1. Technical terms

- a. **Must:** Freshly pressed fruit juice (usually grape juice) that contain the skins, seeds, and stems of the fruit; a mixture of the pomace and juice.
- b. **3-A Standards & Accepted Practices:**
3-A Sanitary Standards, Incorporated
www.3-a.org
- c. **Pressure Vacuum Relief (PVR):** A device to prevent excessive pressurization or vacuum to a fermentation vessel due to abnormal conditions above or below a safe operating pressure.

2. Terms

- a. **Could:** possibility; not emphatic
- b. **Might:** an uncertainty; a possibility
- c. **Must:** certainty; emphatic
- d. **Shall:** emphatic; an obligation
- e. **Should:** awareness of a potential cause or action, but a potential unwillingness to follow the direction
- f. **Would:** a condition; may have been done under different circumstances

3. Potential Ethanol Release during Wine Fermentation:

- a. **Lynn Williams formula:**

$$\text{LOG}_{10} \left[\frac{\text{EtOH}_{\text{potential loss}}}{(S_0 - S)^2} \right] = K_4 - \frac{K_5}{T + 273}$$

Formula converted for potential EtOH release:

$$\text{EtOH}_{\text{potential release}} \text{ in grams per Liter}_{\text{must}} = 10^{\left\{ K_4 - \left[\frac{K_5}{T + 273} \right] - \text{LOG}_{10} \left[\frac{1}{(S_0 - S)^2} \right] \right\}}$$

where,

- Brix_{start} = degrees Brix, start
 Brix_{finish} = degrees Brix, finish
 K₄ = 6.682 (constant)
 K₅ = 2552 (constant)
 T = must temperature in degrees Celsius

$$S_0 = \left[\frac{1}{1 - \left(\frac{\text{Brix}_{\text{start}}}{261.3} \right)} \right] \times 1000$$

$$S = \left[\frac{1}{1 - \left(\frac{\text{Brix}_{\text{fini}}}{261.3} \right)} \right] \times 1000$$

b. CARB 5.1 Factor:

1. Red Wine: 6.2-lbs per 1,000-gallons_{must}

2. White Wine: 2.5-lbs per 1,000-gallons_{must}

3. Ethanol Data:

- a. Weight per US Gallon: 6.584 pounds
- b. Molecular Formula: C_2H_6O
- c. Appearance: colorless liquid
- d. Molar Mass: 46.06844 g/mol
- e. Boiling Point: 173°F, 78.37°C, 352-K
- f. Flash Point: 13°C (55.4°F)
- g. Vapor Pressure: 5.95 kPa (20°C)
- h. Density: 789 kg/m³
- i. Acidity (pK_a): 15.9
- j. Refractive Index (n_D): 1.361 (20°C)
- k. Viscosity: 1.200 cP (20°C)
- l. Solubility in water: miscible
- m. Hazard (Fire): Flammable (F)

n. NFPA 704:

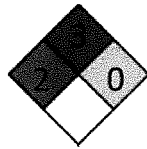

o. Classification:



Appendix B – Drawings

1. General Arrangement
 - a. Horizontal Orientation; generic operation configuration
 - b. Vertical Orientation; generic operation configuration
 - c. Horizontal Orientation; testing configuration

2. Explosion View Drawing
 - a. Horizontal Orientation
 - b. Vertical Orientation
 - c. Demonstration Configuration

3. Process & Instrumentation Drawing
 - a. Vertical Orientation
 - b. Horizontal Orientation
 - c. Horizontal Orientation; testing configuration

EcoPAS

PAS-100

Intro

The EcoPAS PAS-100 system is a smart condenser that captures ethanol emissions from primary fermentation during winery processing. The system uses glycol with a tube-in-shell condenser, custom designed to provide high capture efficiency, at a wide range of flow conditions, without negative impacts on the winemaking process (i.e., high headspace backpressure). CO₂ released during fermentation is the driving force and carrier gas.

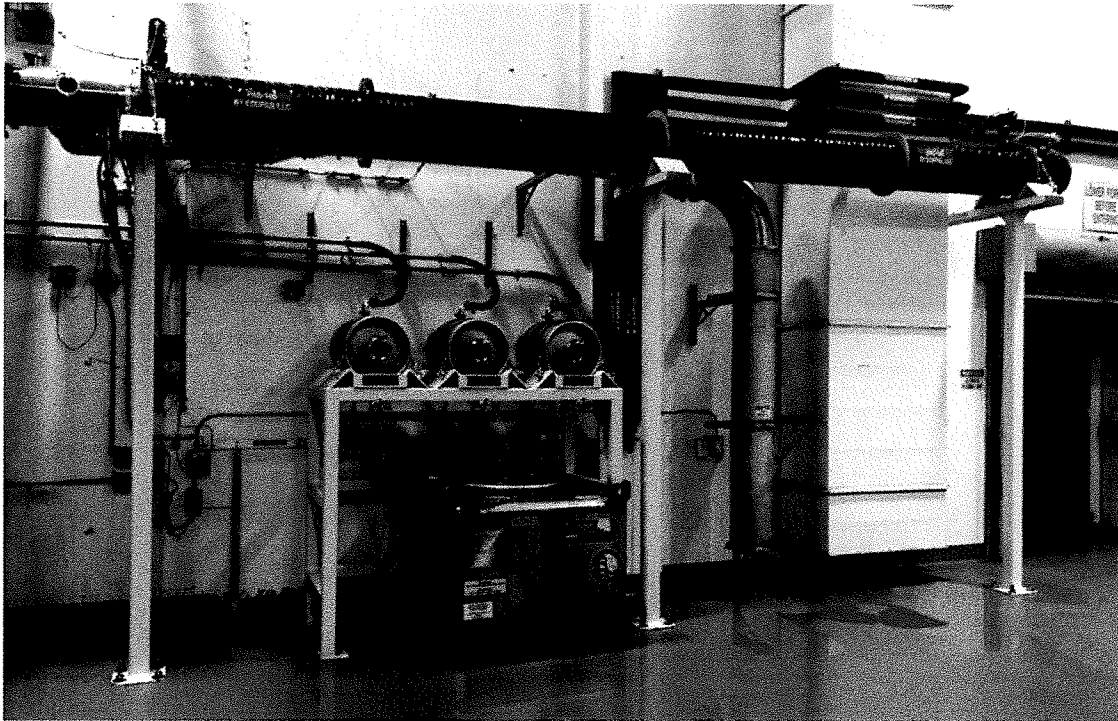
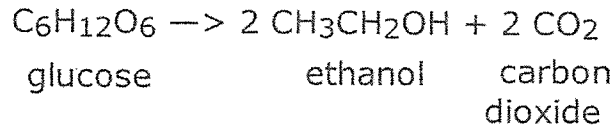

Figure 1: PAS-100, Operational since 2015 at Central Coast Wine Services

Operational Description

Wine fermentation is a biological batch process governed by yeast digestion of grape sugars. Carbon dioxide (CO₂) production and ethanol emission change over the batch process and there is never a steady-state condition during a fermentation cycle.

The stoichiometry is well understood. When yeast ferment juice into wine, one mole of sugar is converted to equal molar amounts of carbon dioxide (CO₂), and ethanol (EtOH):



The majority of CO₂ produced and a fraction of EtOH produced are lost to the atmosphere. Some useful facts for this process:

1. Wine grapes are typically 20-25% sugar by weight
2. Each volume of wine produces approximately 60 volumes of CO₂
3. EtOH is a polar compound, with one of the highest Henry's Law Constants, it easily hydrates and resists leaving the liquid phase
4. Vaporized EtOH is carried from the developing wine with the CO₂ carrier gas
5. Yeast fermentation is an exothermic process and tank temperatures, without active cooling, can exceed 32°C (90°F)
6. The dominant parameters affecting vapor emission of EtOH are tank temperature and sugar content
7. Fermentation is seasonal and typically occurs between August and November

Fermentation temperature is the single most important factor affecting variation in emission strength for any given starting grape sugar concentration.

(see chart next page)

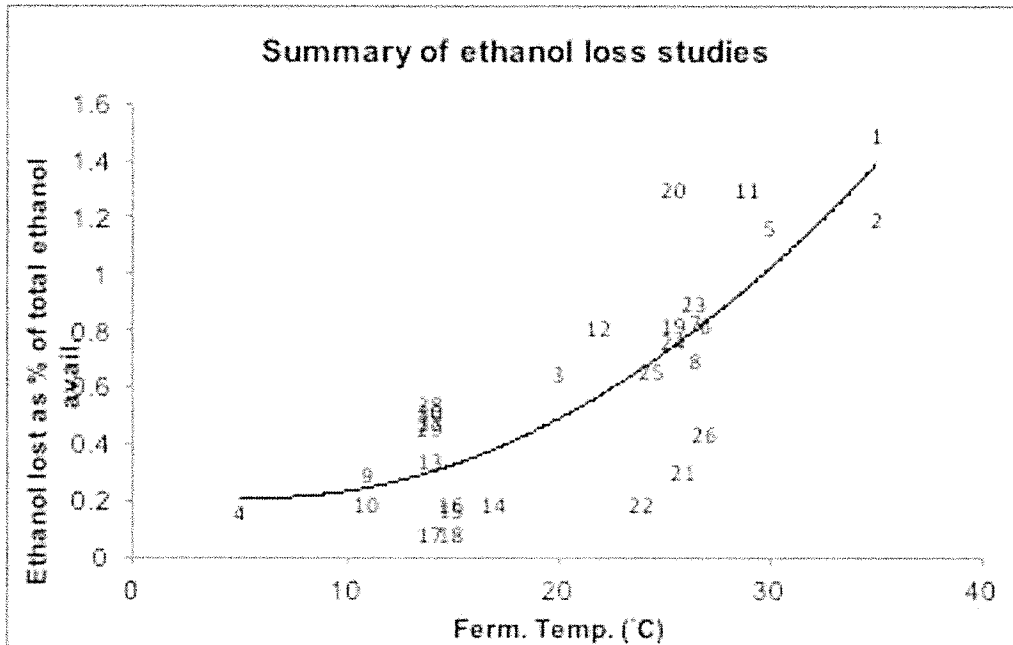

Figure 2: Ethanol lost as a % of total ethanol available with temperature (Fielder and Buamala 1982¹, Todd Castronovo, and Ouchida 1988²).

The following figure presents a modeled single batch fermentation based on a chemical engineering model of wine fermentation. Important for our understanding is the time-dependent profile of sugar consumption, CO₂ production and ethanol emission. The relative positions of the CO₂ and EtOH curves remain the same regardless of the batch duration.

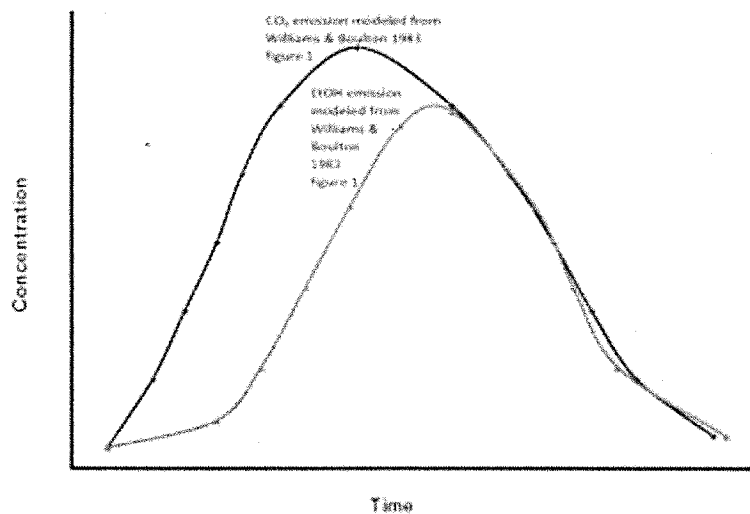

Figure 3: Modeled rates of CO₂ production and ethanol emissions. (Williams and Boulton 1983³).

The PAS-100 system captures fugitive aromatic volatiles and ethanol vapor from wine fermentation. The resulting byproduct is a ~80-proof highly-aromatic spirit, that may have value. For example, it can be used to enhance the original wine, to “repair” a wine that might have lost aromatics somehow, to cross-blend, or to be sold separately as a wine spirit (vodka, brandy, grappa, etc.) EcopAS has also demonstrated that the byproduct can be dehydrated or distilled up to be sold as a “Wine Spirits Addition” (or WSA) without loss of volatile aromatics.

Ground-level ozone forms with the chemical reaction of UV sunlight, nitrogen oxides and volatile organic compounds (VOCs) in the atmosphere. Ethanol vapor is a VOC, and California wineries thousands of tons of VOCs each year during a compressed period of time. Among other health impacts, Ozone is known to cause inflammation and damage to the lining of the lungs. The damaged lung cells are shed and replaced much like the skin peels after a sunburn. When this type of inflammation happens repeatedly, lung tissue becomes permanently scarred, resulting in permanent loss of lung function and a lower quality of life.

California has some of the worst air quality in the nation, including the most number of areas designated by the EPA as severe ozone non-attainment zones.

The PAS-100 system enables wineries to cost-effectively make a positive impact of air quality. And, as markets are made for the aromatic byproducts, it is possible that the “waste” stream can even become a profit center.

The PAS-100 may be installed on a single tank or multi-tank configuration. May be mounted to a catwalk, ferment tank, post, cart, wall or support structure. No electrical, compressed air or natural gas required.

References

¹Fielder, D.R., and P.A. Baumala 1982. Characterization of ethanol emissions from wineries. Research Division California Air Resource Board. Fig.13 p.53.

²Todd, D.F., C.L. Castronovo, and P.K. Ouchida 1988. Ethanol emissions control for wine fermentation tanks. Report #ARB/ML88-027, California Air Resource Board, Monitoring and Lab Division.

³Williams, L.A., and R. Boulton 1983. Modeling and prediction of evaporative loss during wine fermentations. Am. J. Enol. Vitic. 34:234-242.

Specifications (Also see attached Drawings)

- Weight: 735-lbs dry & uninsulated
Dimensions: 25'-long x 1.5'Ø
Capacity: 115,000-gallons at 85°-F / 12°-Bx redux daily
(310-ft³/min 24-hr average)
Connection: Entry: 6"Ø tri-clamp
Exit: 12"Ø tri-clamp
Material: T304-SS (RA32 finish); T316-SS available
Connections: Tri-clamp with PTFE gaskets
Refrigerant: 57-gallons Glycol
Insulation: Jackets are made to be easily removed and to replaced, ensuring energy efficiency will not get in the way of regular maintenance. The jackets are made with a hook and loop straps, or 1 inch buckles and D-rings. Jackets are made with high-quality and state of the art materials by USA manufactures. Utilize heat resistant thread and jacketing to ensure the jacket can handle high temperatures, and use fully hydrophobic aerogel insulation or Glass mat, type E needled fiber as insulation. The components are sown together, ensuring the insulation interior is actively sewn into to jacket to prevent shifting. The result is a high quality durable jacket, able to withstand extreme temperatures and removal without losing quality or functionality.

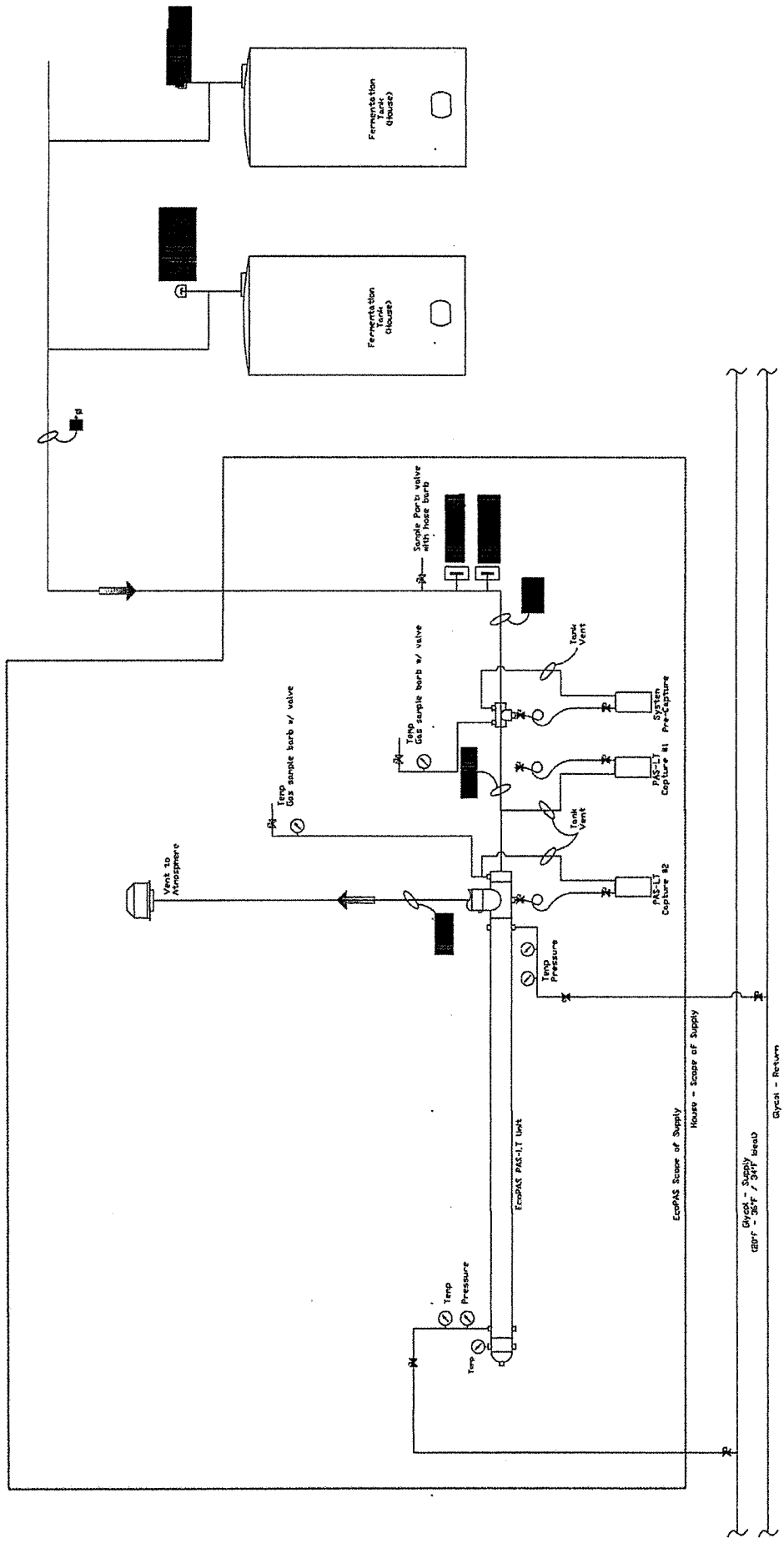

NOTES:

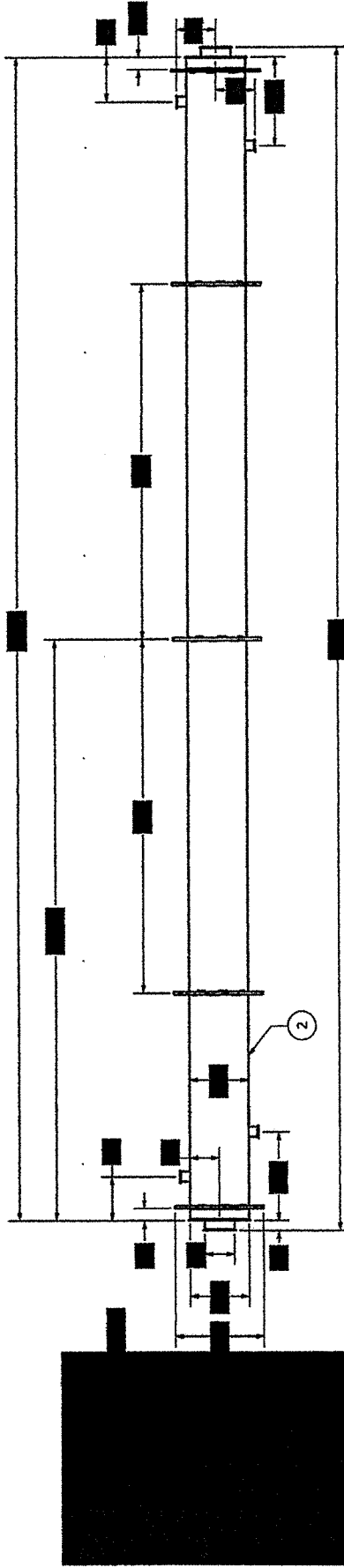
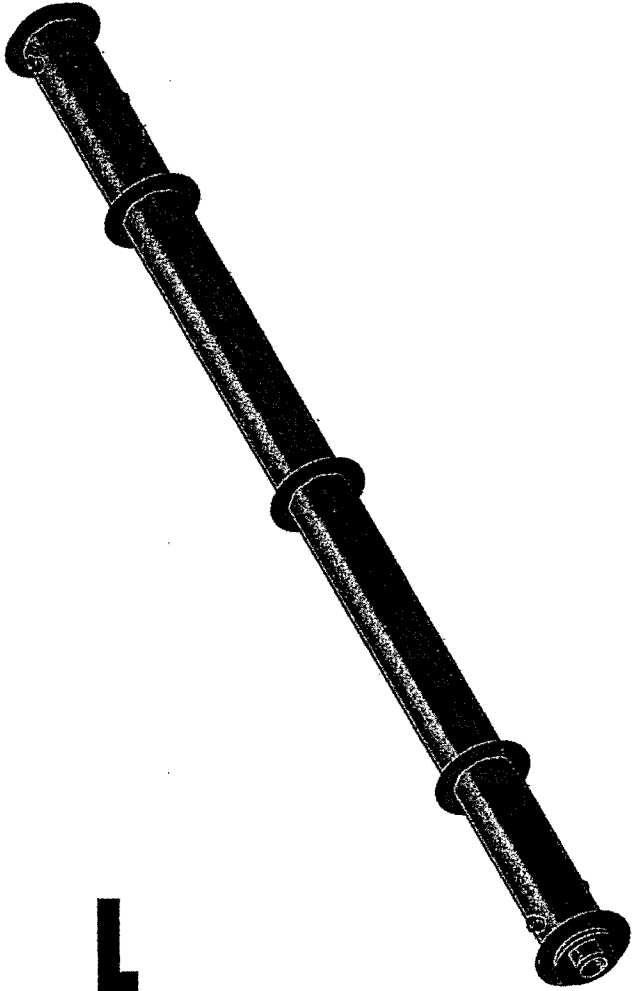

CRITICAL END

NOTE: THIS DRAWING EMBODIES A CONFIDENTIAL PROPRIETARY DESIGN ORIGINATED BY EcOPAS, LLC, AND ALL DESIGN, MANUFACTURING, REPRODUCTION, USE AND SALES RIGHTS REGARDING THE SAME ARE EXPRESSLY RESERVED. IT IS SUBMITTED UNDER A CONFIDENTIAL RELATIONSHIP FOR A SPECIFIC PURPOSE, AND THE RECIPIENT AGREES BY ACCEPTING THIS DRAWING NOT TO SUPPLY OR DISCLOSE ANY INFORMATION REGARDING IT TO ANY UNAUTHORIZED PERSON, OR TO INCORPORATE IN OTHER PROJECTS ANY SPECIAL FEATURES PECULIAR TO THIS DESIGN. ALL PATENT RIGHTS ARE EXPRESSLY RESERVED BY EcOPAS, LLC.

| | | | |
|----------|------------|----------------------|------------|
| DRAWN | 12/10/2012 | EcOPAS, LLC | |
| CHECKED | | TITLE | |
| QA | | Condenser, Assembled | |
| MFG | | SIZE | DWG NO |
| APPROVED | | C | 1002.517.0 |
| | | SCALE | 1/16" SIZE |
| | | REV | |

| ITEM | QTY | PARTS LIST | DESCRIPTION |
|------|-----|------------|-------------------------|
| 1 | 1 | 1002.516.0 | Condenser, Inner Barrel |
| 2 | 1 | 1002.510.1 | Condenser Shell |



| PARTS LIST | | |
|------------|-----|--------------------------------|
| ITEM | QTY | PART NUMBER |
| 1 | 1 | 1002.517A.0 |
| 2 | 1 | 1002.636.0 |
| 3 | 1 | 1002.632.0 |
| 4 | 1 | 1002.518.0 |
| 5 | 1 | 1002.522.0 |
| 6 | 1 | 1002.525-working.0 |
| 7 | 1 | 1002.526-12.0 |
| 8 | 1 | 1002.526-18.0 |
| 9 | 1 | 1002.527-1.0 |
| 10 | 1 | 1002.528.0 |
| 11 | 1 | 1002.529.0 |
| 12 | 1 | 1002.530.0 |
| 13 | 1 | 1002.531.0 |
| 14 | 1 | 1002.532.0 |
| 15 | 1 | 1002.610.0 |
| 16 | 1 | 1002.521.0-edit |
| 17 | 1 | 1002.519-G.0 |
| 18 | 1 | 1002.524-Neoprene.0 |
| 19 | 1 | 1002.524-Stainless.0 |
| 20 | 1 | 92198A628 |
| 21 | 1 | washer_0.375 |
| 22 | 1 | TriClamp-6.0 |
| 23 | 1 | 1002.518-A.0 |
| 24 | 1 | 1002.518-C.0 |
| 25 | 1 | 1002.629.0 |
| 26 | 1 | 1002.628.0 |
| 27 | 1 | 1002.518-D.0 |
| 28 | 1 | 1002.518-F.0 |
| 29 | 1 | 1002.518-H.0 |
| 30 | 1 | 1002.518-I.0 |
| 31 | 1 | TriClamp-2.5 |
| 32 | 1 | 1002.524-Silicone.0 |
| 33 | 1 | 1002.523.0 |
| 34 | 1 | TriClamp-3.0 |
| 35 | 1 | 1002.519-L.0 |
| 36 | 1 | 1002.519-K.0 |
| 37 | 1 | 6-TriClamp |
| 38 | 1 | 1002.514.0 |
| 39 | 1 | 55-Gallon_Drum-Closed_Ht ad |

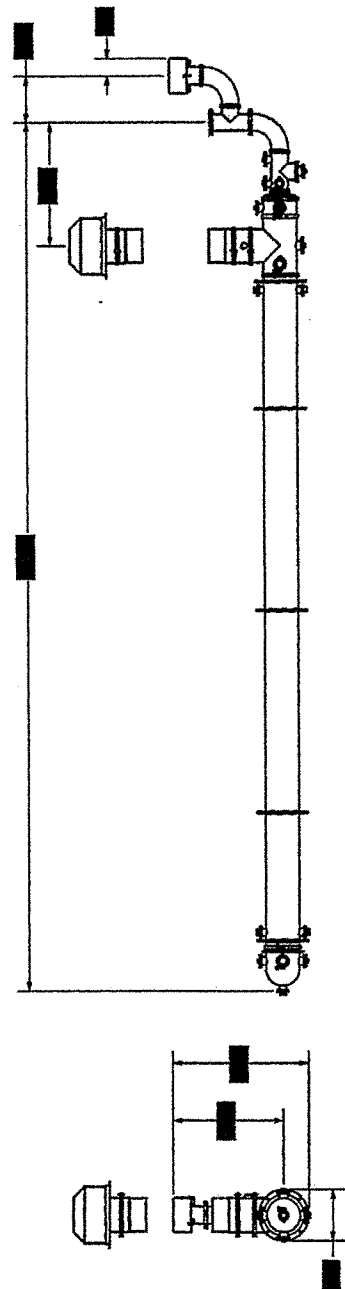

| | | | |
|----------------|----------------------|--------------|----------------------------------|
| DRAWN MRCI | | 1/2/2013 | TITLE |
| CHECKED | | | ECOPAS, LLC |
| QA | | | General Arrangement - Horizontal |
| MFG | | | |
| APPROVED | | | |
| SIZE C | DWG NO 1002.503.0 | REV | |
| SCALE 1/32"=1" | | SHEET 1 OF 1 | |



ECOPAS

*Smart Vapor Systems
for Aroma Capture and
Alcohol Adjustment*

www.eco-pas.com
pthompson@eco-pas.com
949.436.0318

Smart Vapor Systems

Wine fermentation releases significant amounts of fugitive vapors. This "angels' share" is rich with complex volatile aromatic organics. EcoPAS has developed a technology and process for capturing and converting into valuable wine spirits. These unique aromatic wine spirits can be used to enhance wine quality, as a separate grape-based spirit, or as natural flavors or fragrances. EcoPAS offers three modular smart condensing systems:

- PAS-1 (Experimental scale)
- PAS-10 (Artisan scale)
- PAS-100 (Full scale)

Example of complex aromatics in condensate

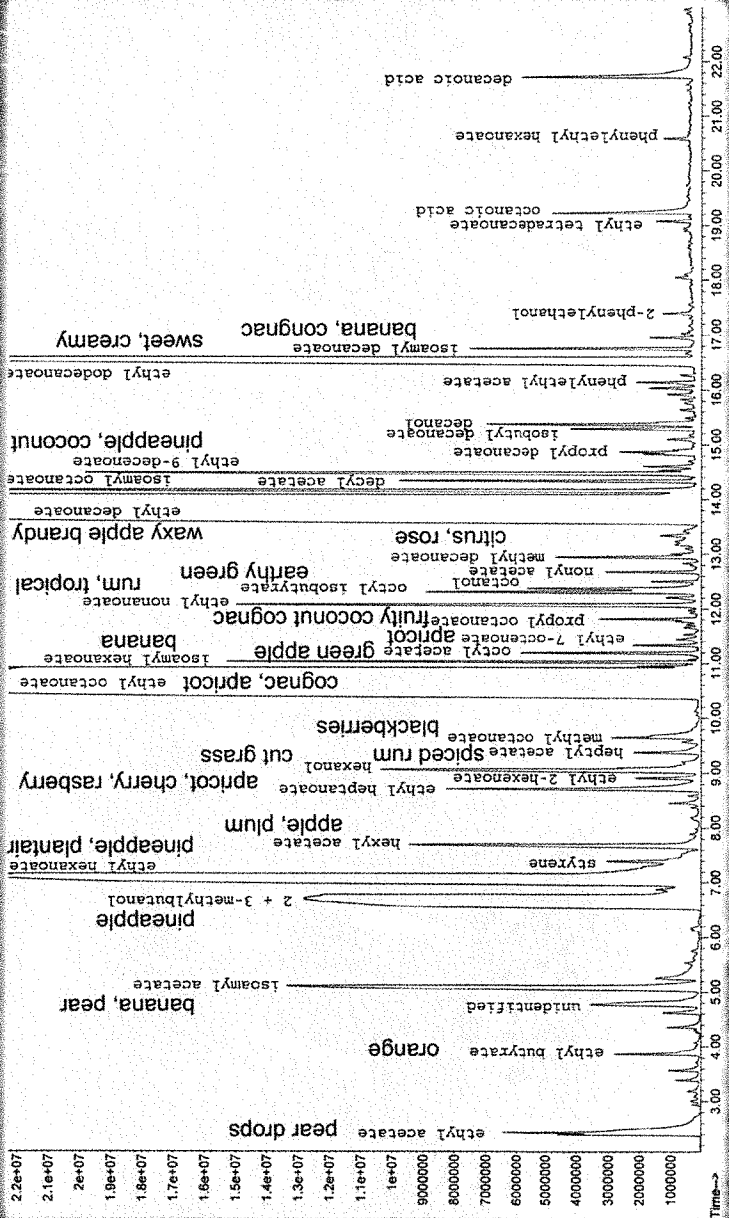

Highly-aromatic wine spirits can enhance wine quality...



Aroma Capture

Key benefits of the patented EcoPAS technologies include:

- Zero water use and zero waste
- Low energy use and small footprint
- Self cleaning and low maintenance
- Yields valuable byproduct

Alcohol Adjustment

Recirculating purified CO2 into the headspace of the fermentation vessel enables the winemaker to increase evaporation of ethanol, providing a tool for reducing effective conversion ratio, without loss of desirable aromatics.

Carbon Capture

Cool, clean CO2 can be compressed and used or sold, displacing fossil sources, and resulting in carbon-negative winery operations.

Attachment C

NohBell's NoMoVo Technology



**Santa Barbara County
Air Pollution Control District**

Our Vision: Clean Air

BACT ANALYSIS SUMMARY FORM

This form must be submitted by all applicants when Best Available Control Technology ("BACT") is required, except for small sources that utilize BACT as listed on the APCD's *Small Source BACT List*, for which case this form is not required. This form supplements APCD Regulation II and applicable APCD application guideline documents. Please fill in all sections of this form completely. Also, fill in a separate form for each emissions unit subject to BACT (multiple units with the same BACT may use only one form). Use additional sheets as necessary.

COMPANY NAME: Central Coast Wine Services (CCWS) DATE: April 20, 2017

FACILITY\SOURCE NAME: Central Coast Wine Services – Santa Maria Winery

1. POLLUTANT(S) SUBJECT TO BACT REVIEW: ROC (Ethanol)

2. EMISSION UNIT(S)/PROCESS(ES) SUBJECT TO BACT REVIEW: Closed Tank Fermentation

3. BACT SUMMARY:

Technology: Vapor Absorption – NoMoVo by NohBell

Performance Standard: To be Determined – NohBell has provided CCWS with a performance guarantee of 67.5%. However this control efficiency has not been validated. Limitations of the capture system were attempted to be taken into consideration. Only with proper validation can a real control efficiency be assigned to this combination of vapor capture and ethanol extraction from the vapor stream be assessed.

Performance as described is only valid when determined by the existing mass-balance process.

4. BACT SELECTION PROCESS DISCUSSION: On a separate sheet of paper, describe the justification for the selected control technology as BACT. Include the following in your description: documentation of technical infeasibility which would preclude the use of a more effective control technology; operating conditions at which the maximum daily and hourly emissions will be generated (baseline parameters); maximum daily and hourly emissions at the baseline conditions and the basis of how the emission rates were estimated; calculations, emission data, and/or other information to determine control effectiveness of each potential control technology; and emission limits expressed both in terms of an emissions cap (e.g., pounds per day) and in terms which ensure compliance at any operating capacity (e.g., pounds per million British thermal units, or parts per million by volume).

APPLICATION No

5. BACT EFFECTIVENESS: Discuss how BACT will be effective over all operating ranges.

The performance of this technology is not consistent over the entire duration of a fermentation cycle. Absorption performance can vary from 45% to 90+% depending upon the timing of the fermentation cycle. Compound that variability with the normal insistent operations of the capture manifold, and the actual variability of the control efficiency across all operating ranges in indeterminable.

6. BACT DURING NON-STANDARD OPERATIONS: Discuss whether the proposed BACT is achievable during non-standard operations and if not, what BACT is for those operations.

BACT will not be achievable during non-standard operations. During non-standard operations the control efficiency will be zero. Non-Standard operations are any time the tank man-way is opened to perform normal winemaking operations (e.g. visual inspections or tank pump-overs).

7. OPERATING CONSTRAINTS: Identify all process variables for which operating limits need to be set in order to ensure compliance with the selected BACT standards.

To Be Determined

8. MONITORING BACT: Describe, in detail, how the selected BACT is to be monitored for its emission reduction effectiveness.

Until a source test protocol is promulgated by the US EPA, as has been indicated, effectiveness will be determined by mass balance calculations using existing recordkeeping protocols.

9. ALTERNATE BASIC EQUIPMENT: Discuss whether alternate basic equipment (e.g., electric motors in lieu of IC engines) can be applied to this application.

No alternatives are known

10. Yes No Will this be a multi-year and/or multi-phase project?

11. Yes No Are all referenced documents attached?

12. Yes No If PSD BACT is triggered, was a detailed Top-Down BACT Analysis prepared and submitted with the application? Please be aware that the applicant is responsible for providing the APCD with this analysis.

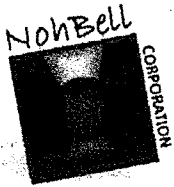

2800—156th AVE SE, STE 200 Bellevue, WA 98007
Telephone 425.223.4253

To: Whom it may concern

Thursday April 20, 2017

From: Ad Verkuylen

NohBell Corporation – VP Engineering

Regarding: NoMoVo Specifications and operational performance guarantee.

The NoMoVo units come in two sizes, 1836 and 2448.

The 1826 unit is sized for 0 - 60,000 gallons actively fermenting (Net tank capacity).

The 2448 unit is sized for 0 - 100,000 gallons actively fermenting (Net tank capacity).

Within normal operating parameters, the units will operate at an efficiency no lower than 67.5% measured over the length of a single fermentation.

At any random time during the fermentation the units will never perform below 45% efficiency.

At a large portion of the time during fermentation, the units will operate at 90+% efficiency.

The above take into account normal winery operation parameters, including temporary opening of the tank hatch for pump-overs and inspections.

Respectfully,

Ad Verkuylen

NohBell Corporation – VP Engineering



Fermentation Exhaust Cleaner

1 Introduction

During recent developments in California, state, local and regulatory agencies have shown an increased awareness and sensitivity in regard to Green House Gasses (GHG) emissions. This has started to hit upon the wine industry, and their generation of GHG's. For the scope of this document we will be addressing this issue specifically focused on the fermentation process. While there are other instances of GHG creation (storage both tank and barrel) by order of magnitude, the fermentation is a multitude larger than the next largest cause of GHG's.

1.1 Exhaust Gases

The fermentation of wine creates large amounts of Carbon-Dioxide (CO_2). With that CO_2 , small amounts of the volatile organic compound Ethanol (ETOH or $\text{C}_2\text{H}_5\text{OH}$) escape as well. There are some other compounds that get exhausted, but at this time they are deemed to be in such small concentrations that they have no bearing on the scope discussed in this document.

1.2 Legal Limits

- There is currently no specific limit known for CO_2 emissions
- The current legal limit for ETOH emissions is 55 lbs/day.

2 Problem Definition and Constraints

2.1 Process

Making wine, and fermenting is a sensitive subject, some of the CO_2 inside the tanks acts like a blanket over the top of the wine. The proposed solution that is designed will not negatively influence the fermentation process or undue exposure of the wine to oxygen.

2.2 Foodgrade and Cleanliness

This solution also complies with food safety and cleanliness standards as customary in the wine industry. This means that any and all ducting, piping, vessels and other interfaces that are used and/or connected to existing equipment such as fermentation tanks are cleanable by either COP or CIP methods.

2.3 Construction

In review of the existing facility, and the way their fermentation tanks are typically constructed, there is a limit to the amount of equipment that can be placed on top of a tank, or in the immediate vicinity.

Furthermore, these tanks are atmospherically balanced and not built to withstand pressure or vacuum.



2.4 Economic Feasibility

The solution needs to be able to be designed, build and operated inside economic guidelines that are in check with the economic burden that this sort of operation can carry and still remain feasible as a business.

It is also a goal to meet the cost per ton of reduction targets set by the California Air Quality Department.

2.5 Size and Scalability

Fermentation lots come in 3 common sizes (25, 50 and 75 tons) and also have the occasional custom size batch. For the flexibility and scalability, this design will be able to handle a tank up to 75 tons.

3 The NohMoVo Solution

Looking at existing and or similar technologies, a couple of them seem to fit the criteria but for the most part are cost prohibitive and / or operationally not desirable due to cleaning complexity or utility requirements.

Looking at all factors involved, [REDACTED] shows potential with some significant enhancements to ensure efficient extraction and collection of the VOCs. A multi-staged hybrid [REDACTED] [REDACTED] system is proposed. (diagram below) "CONFIDENTIAL INFORMATION REDACTED"

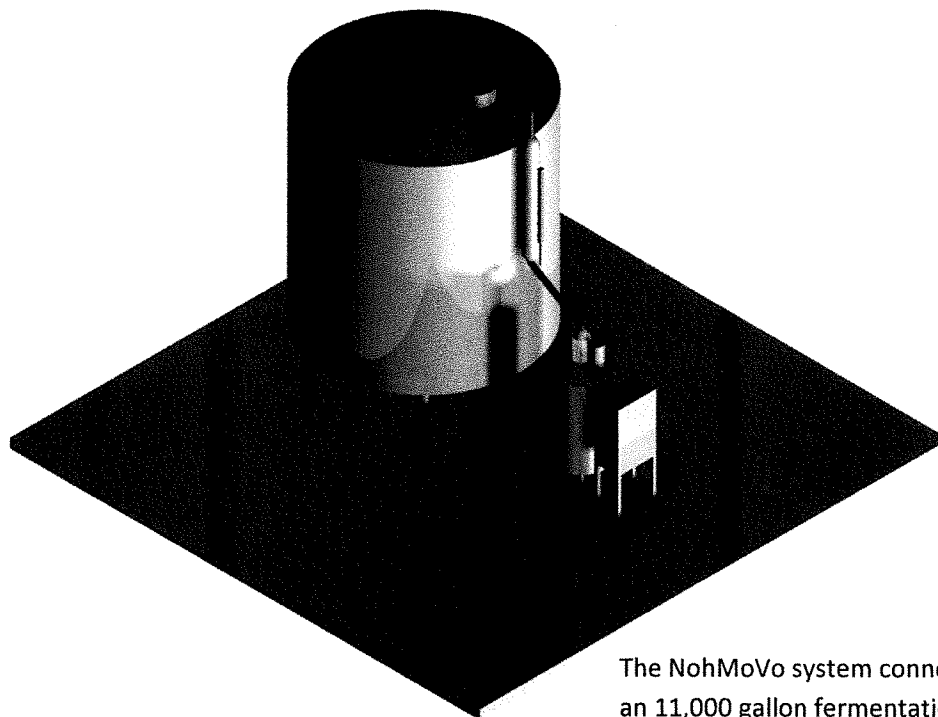

The NohMoVo system connected to an 11,000 gallon fermentation tank.



4 Calculations

4.1 Carbon Dioxide

| Standard Lots | Liters/Lot | l/day | l/hr | l/min | l/s |
|---------------|------------|-----------|----------|--------|-------|
| 25 tons | 1160894.42 | 290223.61 | 12092.65 | 201.54 | 3.36 |
| 50 tons | 2321788.85 | 580447.21 | 24185.30 | 403.09 | 6.72 |
| 75 tons | 3482683.27 | 870670.82 | 36277.95 | 604.63 | 10.08 |

4.2 Alcohol

Standard Lots

| | | | Total Alcohol in liters | | | Alcohol Loss in Liters | | |
|---------|---------|--------|-------------------------|--------|--------|------------------------|-------|-------|
| | | | 10% | 12% | 14% | 10% | 12% | 14% |
| 25 tons | 20819.8 | liters | 2082.0 | 2498.4 | 2914.8 | 32.5 | 39.0 | 45.5 |
| 50 tons | 41639.5 | liters | 4164.0 | 4996.7 | 5829.5 | 65.0 | 77.9 | 90.9 |
| 75 tons | 62459.3 | liters | 6245.9 | 7495.1 | 8744.3 | 97.4 | 116.9 | 136.4 |

5 The Demolieren Reactor System

5.1 Process Flow Diagram

"CONFIDENTIAL INFORMATION DELETED"



5.2 Functional Description

"CONFIDENTIAL INFORMATION DELETED"



6 Testing

6.1 Winery Onsite Testing

- Phase 1 testing is scheduled to occur the week of September 14th, 2009 for 5 days.
- Phase 1 laboratory results evaluation planned for the week of September 21st, 2009 for 2 days.
- Phase 2 testing (if required) is scheduled for the week of September 28th, 2009 for 5 days.
- Phase 1 and 2 evaluation planned for October 5th, 2009.

6.2 Testing Procedures

The test methodology will follow the guidelines already in place at the test winery and will initially utilize the onsite laboratory and equipment to perform the necessary analysis for ETOH concentrations.

Samples will be taken every hour during the fermentation cycle to accurately plot concentration rates and to evaluate saturation levels. Based on the typical fermentation cycle of 4 to 7 days, sufficient data points (96 to 168) will be charted to determine the general efficiency of the NohMoVo collection system over the course of the cycle. The results of this Phase 1 test will determine additional data collection requirements for Phase 2 tests.

6.2.1 Phase 1

In the first phase of site testing, liquid samples will only be taken from the tank to determine the amount of ETOH captured in the slurry versus theoretical calculations.

6.2.2 Phase 2

Assuming successful results in the initial phase of the testing, the second phase of tests will continue to collect slurry samples along with gas samples at both the inlet to the Reactor Column and from the discharge of the Demolier Slurry tank. The planned method will be to collect sealed onsite samples to be later tested at an offsite laboratory equipped to measure ETOH at low concentrations.

6.3 Operational Efficiency

System efficiency levels are currently calculated to be approximately 80 to 85 percent with respect to the removal of ETOH from the fermentation offgassing. It is anticipated that actual capture rates will vary as a result of product types, yeast cultures, alcohol levels, balancing gas additions and atmospheric conditions.



7 Next Steps

7.1 Winery Approval

This approach has been presented to the client and has been given initial approval. This document is the final submittal of intent to test the NohMoVo Control System.

7.2 SBCAPCD Submittal and Approval

This document and attached drawing are to be submitted by the client for testing approval.



Fermentation Exhaust Cleaner

(SBCAPCD Information Request – Addendum)

1 Overview

Additional information was requested by the SBCAPCD as a result of a meeting held with CCWS on July 15th, 2009. A conversation held with Mr. Lunt of CCWS and subsequent e-mail (excerpt below) summarizes the request.

"The APCD has follow up questions related to understanding how the NohMoVo system under test in harvest 2009 can be applied as operable equipment for emission control at Central Coast Wine Services by harvest of 2010. They are requesting further information regarding how the equipment will be portable from tank to tank as fermentations finish in any particular tank and begin in another tank, how the equipment can be manifolded to join multiple tanks to a NohMoVo unit, how VOC or emission tests will be performed (test procedures), and how efficiencies will be calculated (mathematical examples)."

We will address these questions to the best of our ability and based on the information we have developed during the course of the systems design and scaled testing. The subsequent sections will address the questions individually.

2 Equipment Portability

2.1 Skid Mount Design

As was noted in section 5.2 of the initial submittal;



"CONFIDENTIAL INFORMATION REDACTED"

A more detailed image of the major components, mounted on the skid is shown in diagram 1. The skid will be approximately 48" x 60" and will have slotted channels to be moved by fork truck or pallet jack. Post fermentation, the Reactor Column outlet and the Slurry Recycle line, will be disconnected from the Slurry Tank. The skid is powered from a single 230VAC-3PHS flexible cable and can be disconnected at the skid.

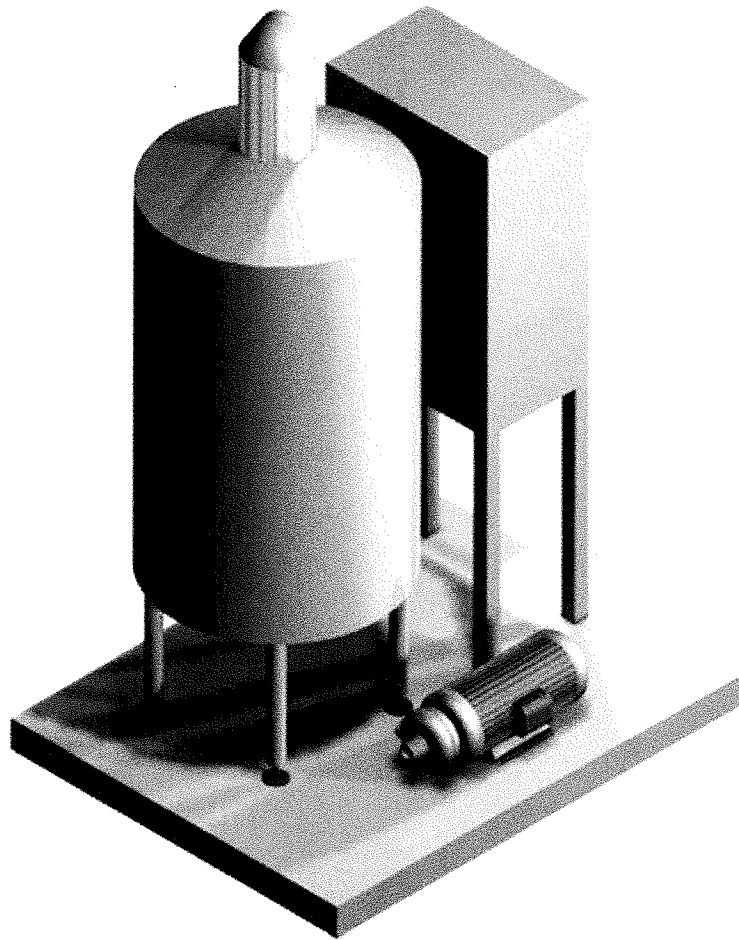

Diagram 1 – Portable Skid Mounted Components

2.2 Transfer to Subsequent Fermentation Tanks

The disconnecting, CIP and relocation of the Demolier tank Skid is tool less and can be completed without concern for the product in the Fermentation Tank. [REDACTED]

[REDACTED]

"CONFIDENTIAL INFORMATION REDACTED"

2.3 Multiple Tank Connection

[REDACTED]



[REDACTED]

"CONFIDENTIAL INFORMATION REDACTED"

3 VOC and Emission Testing

As noted in section 4 of the initial submission, based on typical red wine fermentation cycles, one can expect between 78 to 91 liters (17.5 to 20 gallons) of ETOH to be carried out of the tank via CO2 off gassing for a 50 ton (11,000 gallon) batch.

Standard Lots

| | | | Total Alcohol in liters | | | Alcohol Loss in Liters | | |
|---------|---------|--------|-------------------------|--------|--------|------------------------|-------|-------|
| | | | 10% | 12% | 14% | 10% | 12% | 14% |
| 25 tons | 20819.8 | liters | 2082.0 | 2498.4 | 2914.8 | 32.5 | 39.0 | 45.5 |
| 50 tons | 41639.5 | liters | 4164.0 | 4996.7 | 5829.5 | 65.0 | 77.9 | 90.9 |
| 75 tons | 62459.3 | liters | 6245.9 | 7495.1 | 8744.3 | 97.4 | 116.9 | 136.4 |

The testing will be carried out as described in section 6 of the initial submittal and will utilize the following instruments and methods;

- a) Field sampling and on site lab testing will initially use a hydrometer to test the specific gravity of the liquid in the Slurry Tank. The system is initially charged with [REDACTED] and will be used as a basis to determine the alcohol percentage in the slurry. "CONFIDENTIAL INFORMATION REDACTED"

Product samples will be collected in 750ml glass containers directly from the sample port on the slurry tank. Samples will be time stamped relative to the fermentation cycle. Sample sizes of this quantity are required due to the volume of liquid required to perform a hydrometer test.

- b) Based on field sampling and initial on-site laboratory tests, secondary tests will be performed both in the on-site and preselected off-site laboratories. This secondary test will utilize a refractometer to analyze the alcohol levels in the slurry and off-gas samples. At the current time, it is planned to utilize the laboratory services of COBE Industrials located in Pico Rivera, CA as the off-site testing service.

Product samples for this phase of testing will be collected using 25ml sterilized syringes directly from the slurry tank, [REDACTED]. It may be necessary to measure the air stream samples utilizing a gas chromatograph due to the low levels in the sample size, which COBE Industrials are capable of performing. "CONFIDENTIAL INFORMATION REDACTED"



4 Efficiency Calculations

4.1 Discussion

As was noted in section 6.3 of the initial submission;

“System efficiency levels are currently calculated to be approximately 80 to 85 percent with respect to the removal of ETOH from the fermentation off gassing. It is anticipated that actual capture rates will vary as a result of product types, yeast cultures, alcohol levels, balancing gas additions and atmospheric conditions.”

The objective of the system is to [REDACTED]. As noted above the amount of VOCs for any given fermentation will vary and in some cases significantly. The calculations noted in section 4.1 of the original submission and again in section 3, the most conservative numbers have been used. “CONFIDENTIAL INFORMATION REDACTED”

4.2 Efficiencies

The initial efficiency of the system will be calculated using total amount of ETOH collected throughout the entire fermentation cycle versus theoretical emission volumes.

Example:

For an 11,000 gallon batch of red wine at a finished alcohol percentage of 12%, theoretical calculations tell us that will yield approximately 78 liters of ETOH loss via fermentation tank emissions during entire cycle. The slurry tank will be charged with 225 liters of water at the start of the cycle and is expected to effectively extract to a 30% ETOH concentration or 67.5 liters. This would effectively result in an 85% efficiency removal of ETOH from the off-gas stream.

Further efficiency analysis will be carried out assuming successful results in the first phase of testing.

| | | VOC (ETOH) Extraction Efficiency | | | | | |
|----------------------------------|--------------------|----------------------------------|-------|-------|-------|-------|-------|
| | | 0.0% | 55.0% | 75.0% | 80.0% | 85.0% | 90.0% |
| released / 11,000 gal tank | VOC liters / cycle | 77.95 | 35.08 | 19.49 | 15.59 | 11.69 | 7.79 |
| | VOC liters / day | 19.49 | 8.77 | 4.87 | 3.90 | 2.92 | 1.95 |
| | VOC pounds / day | 33.90 | 15.26 | 8.48 | 6.78 | 5.09 | 3.39 |

VOC Emissions per 11,000 gallon Fermentation Tank at various capture efficiencies.



5 Next Steps

5.1 Winery Approval

This approach has been presented to the client and has been given initial approval. This document is an addendum to the final submittal of intent to test the NohMoVo Control System.

5.2 SBCAPCD Submittal and Approval

This document is to be submitted by the client for testing approval.

About NohBell Corporation

We are a Think Tank. Clients hire us to craft the integration of current and emerging technologies with traditional business and manufacturing operations. The objective creates seamless transitions that provide measurable benefits with each project.

- ◇ Knowledge
- ◇ Creativity
- ◇ Integration
- ◇ Execution

—It's what we are about

- NohBell is a firm of industry professionals dedicated to practicing the art of solving complex business problems
- Over 100 years cumulative experience in the wine and beverage industries
- Experts in production efficiency and supply chain optimization
- NoMoVo™ equipment developed by and for the wine industry

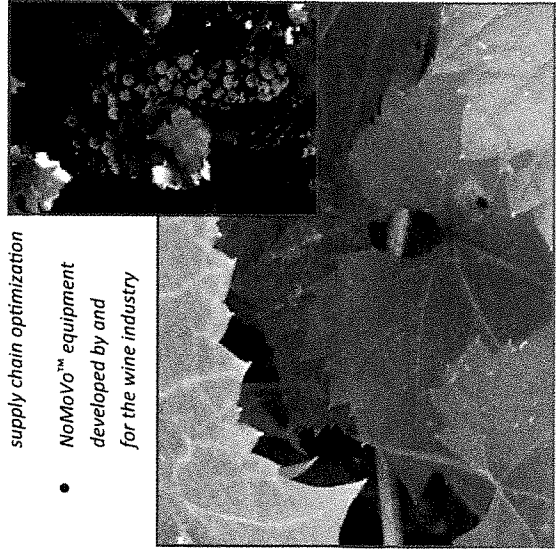

FEATURES

- Fermentation Emissions Control
- Capture ETOH
- Manage CO₂



A Division of NohBell Corp.

Michael Keneipp, CEO
 mk@nohbell.com
 425.443.0883

Ad Verkuylen, VP Engineering
 av@nohbell.com
 208.440.2323

Corporate Headquarters
 2800 156th AVE SE, STE 200
 Bellevue, WA 98007
 425-223-4253
 www.nohbell.com

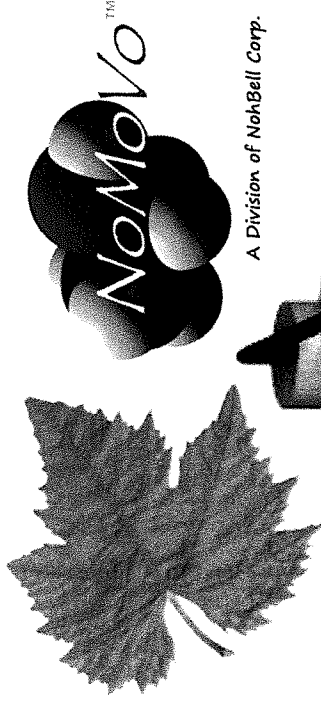

A Division of NohBell Corp.

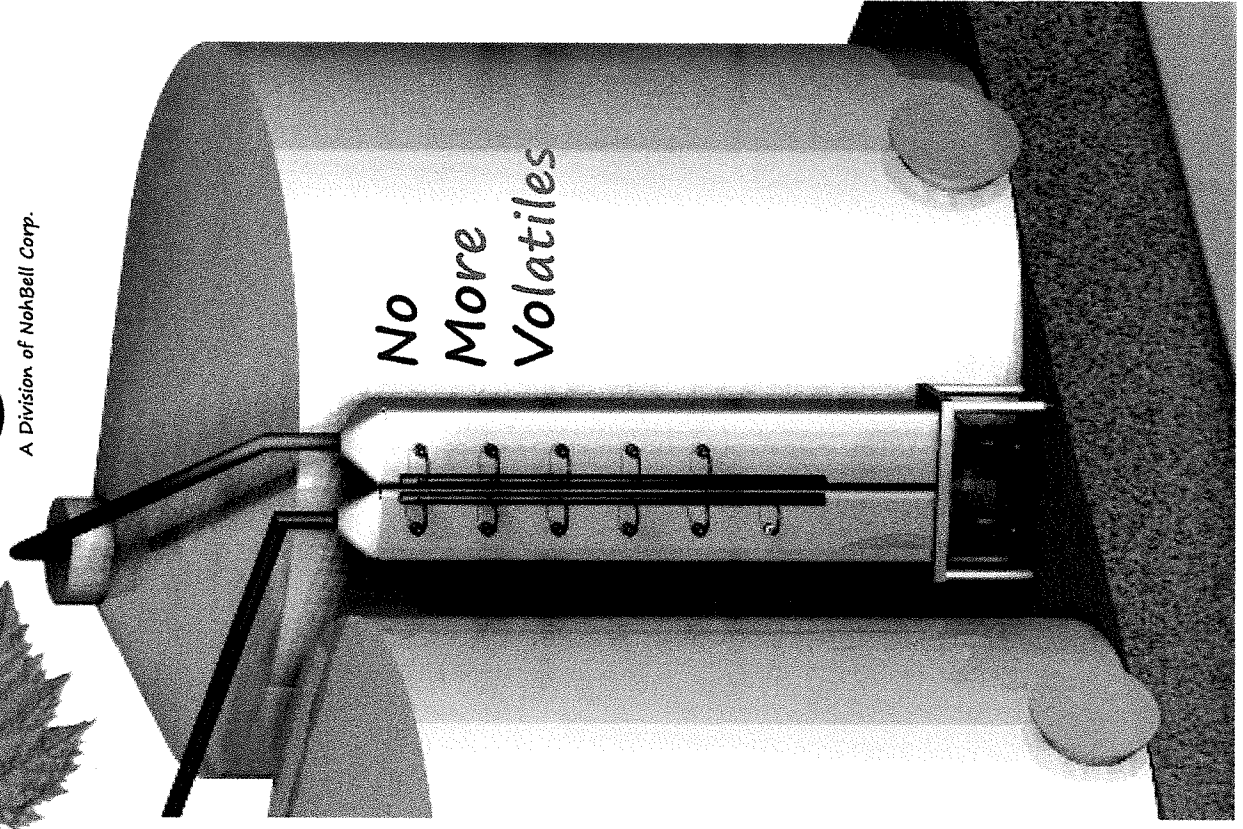

ISSUE

The fermentation of wine creates and emits relatively large amounts of Carbon-Dioxide (CO₂) and the volatile organic compound Ethanol (ETOH or C₂H₅OH). Acetaldehyde, methyl alcohol (methanol), n-propyl alcohol, n-butyl alcohol, sec-butyl alcohol, isobutyl alcohol, isoamyl alcohol, and hydrogen sulfide also are emitted but in much smaller quantities compared to ethanol emissions.

'The Environmental Protection Agency is drafting Green House Gas legislation including hydrocarbon and ozone restrictions'

California's state and district regulatory agencies are demonstrating increased awareness and sensitivity to Green House Gas (GHG) emissions resulting from fermentation processes used to manufacture alcoholic beverages. This has begun to impact the wine industry by way of incremental regulatory oversight and statutory fines. The degree of impact is typically dictated by the volume of regulated GHG's produced by a single entity, in a specific location, as measured against the pre-defined limits for gas emissions in a particular jurisdiction.

NoMoVo™

'NoMoVo™ is a dielectric attraction and extraction, "Emissions Capture System," engineered specifically for the wine industry'

- The system is efficient, cost effective, and versatile in adapting to various wine production techniques
- Does not negatively affect the fermentation process or unnecessarily expose wine to oxygen
- In a typical winery, fermentation is by order of magnitude, the largest single source of VOC emissions in winemaking operations.
- Typically, the most significant of the Volatile Organic Compounds (VOCs) is ethanol (ETOH).

Alternative technologies exist and have been proven effective in the removal of VOCs from emissions streams. They are designed to either selectively remove or thermally destruct the VOCs. All other solutions have proven either inefficient, cost prohibitive, or have the added burden of operational complexity, significant sanitation concerns, and large utility requirements.

FEATURES

- Food safety and cleanliness standards compliant
- Cleanable by COP or CIP methods
- Small footprint—space efficient, easily configurable
- Cap management enabled
- Can be disconnected, cleaned and moved without special equipment or tools

